

(19) World Intellectual Property
Organization
International Bureau



(43) International Publication Date
2 December 2004 (02.12.2004)

PCT

(10) International Publication Number
WO 2004/103497 A1

(51) International Patent Classification⁷: A63F 9/08

CO, CR, CU, CZ, DE, DK, DM, DZ, EC, EE, EG, ES, FI, GB, GD, GE, GH, GM, HR, HU, ID, IL, IN, IS, JP, KE, KG, KP, KR, KZ, LC, LK, LR, LS, LT, LU, LV, MA, MD, MG, MK, MN, MW, MX, MZ, NA, NI, NO, NZ, OM, PG, PH, PL, PT, RO, RU, SC, SD, SE, SG, SK, SL, SY, TJ, TM, TN, TR, TT, TZ, UA, UG, US, UZ, VC, VN, YU, ZA, ZM, ZW.

(21) International Application Number:
PCT/GR2004/000027

(22) International Filing Date: 13 May 2004 (13.05.2004)

(25) Filing Language: English

(84) Designated States (unless otherwise indicated, for every kind of regional protection available): ARIPO (BW, GH, GM, KE, LS, MW, MZ, NA, SD, SL, SZ, TZ, UG, ZM, ZW), Eurasian (AM, AZ, BY, KG, KZ, MD, RU, TJ, TM), European (AT, BE, BG, CH, CY, CZ, DE, DK, EE, ES, FI, FR, GB, GR, HU, IE, IT, LU, MC, NL, PL, PT, RO, SE, SI, SK, TR), OAPI (BF, BJ, CF, CG, CI, CM, GA, GN, GQ, GW, ML, MR, NE, SN, TD, TG).

(26) Publication Language: English

(30) Priority Data:
20030100227 21 May 2003 (21.05.2003) GR

(71) Applicant and

(72) Inventor: VERDES, Panayotis [GR/GR]; Next to Hotel Amalia, GR-211 00 New Tirynta, Nafplio (GR).

Published:
— with international search report

(81) Designated States (unless otherwise indicated, for every kind of national protection available): AE, AG, AL, AM, AT, AU, AZ, BA, BB, BG, BR, BW, BY, BZ, CA, CH, CN,

For two-letter codes and other abbreviations, refer to the "Guidance Notes on Codes and Abbreviations" appearing at the beginning of each regular issue of the PCT Gazette.

(54) Title: CUBIC LOGIC TOY

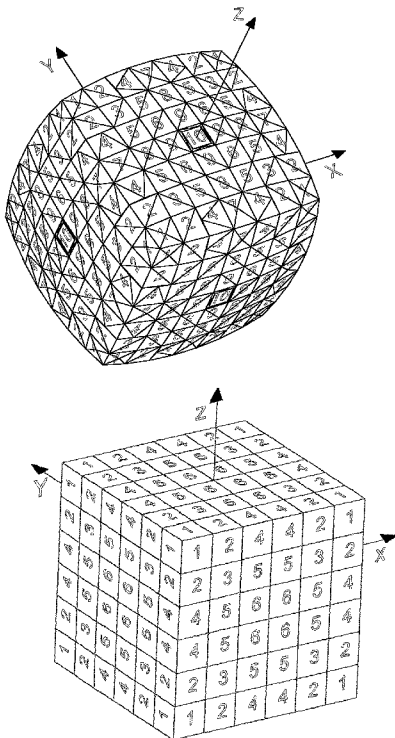

(57) Abstract: This is an invention that concerns the construction of three-dimensional logic toys, which have the shape of a normal solid, substantially cubic in shape, and N number of layers in each direction of the three-dimensional rectangular Cartesian coordinate system, said layers consisting of smaller separate pieces. Their sides that form part of the solid's external surface are substantially cubic. The said pieces can rotate in layers around the three-dimensional axes of the coordinates; their visible rectangular surfaces can be colored or they can bare shapes, letters or numbers. The construction is based on the configuration of the internal surfaces of the separate pieces using planar, spherical and mainly right conical surfaces, coaxial to the semi-axis of the coordinates, the number of which is κ per semi-axis. The advantage of this construction is that by the use of these κ conical surfaces per semi-axis, two solids arise each time; the first has an even ($N=2\kappa$) number of layers per direction visible to the user, whereas the second has the next odd ($N=2\kappa+1$) number of visible layers per direction. As a result, by using a unified method and way of construction, for the values of κ from 1 to 5, we can produce in total eleven logic toys whose shape is a normal geometric solid, substantially cubic in shape. These solids are the Cubic Logic Toys No N, where N can take values from $N=2$ to $N=11$. The invention became possible after we have solved the problem of connecting the corner piece with the interior of the cube, so that it can be self-contained, can rotate unobstructed around the axes of the three-dimensional rectangular Cartesian coordinate system and, at the same time, can be protected from being dismantled. This invention is unified and its advantage is that, with a new different internal configuration, we can construct - apart from the already known cubes $2 \times 2 \times 2$, $3 \times 3 \times 3$, $4 \times 4 \times 4$, $5 \times 5 \times 5$ which have already been constructed in many different ways and by different people - the next cubes from $N=6$ up to $N=11$. Finally, the most important advantage is that it eliminates the operational disadvantages that the already existing cubes have, except for the Rubik cube, i.e. $3 \times 3 \times 3$.

WO 2004/103497 A1

CUBIC LOGIC TOY

This invention refers to the manufacturing of three – dimensional logic toys, which have the form of a normal geometric solid, substantially cubic, which has N layers per each direction of the three – dimensional rectangular Cartesian coordinate system, the centre of which coincides with the geometric centre of the solid. The layers consist of a number of smaller
5 pieces, which in layers can rotate around the axes of the three – dimensional rectangular Cartesian coordinate system.

Such logic toys either cubic or of other shape are famous worldwide, the most famous being the Rubik cube, which is considered to be the best toy of the last two centuries.

This cube has three layers per each direction of the three – dimensional rectangular
10 Cartesian coordinate system and it could otherwise be named as 3x3x3 cube, or even better as cube No 3, having on each face 9 planar square surfaces, each one coloured with one of the six basic colours, that is in total $6 \times 9 = 54$ coloured planar square surfaces, and for solving this game the user should rotate the layers of the cube, so that, finally, each face of the cube has the same colour.

15 From what we know up to now, except for the classic Rubik cube, that is the cube No 3, the 2x2x2 cube with two layers per direction, (or otherwise called cube No 2), the 4x4x4 cube with four layers per direction, (or otherwise called cube No 4) and the 5x5x5 cube with five layers per direction,(or otherwise called cube No 5) have also been manufactured.

However, with the exception of the well-known Rubik cube, that is the cube No 3, which
20 does not present any disadvantages during its speed cubing, the other cubes have disadvantages during their speed cubing and the user should be very careful, otherwise the
* cubes risk having some of their pieces destroyed or being dismantled.

The disadvantages of the cube 2x2x2 are mentioned in the U.S. Rubik invention N4378117, whereas those of the cubes 4x4x4 and 5x5x5 on the Internet site www.Rubiks.com, where
25 the user is warned not to rotate the cube violently or fast.

As a result, the slow rotation complicates the competition of the users in solving the cube as quickly as possible.

The fact that these cubes present problems during their speed Cubing is proved by the decision of the Cubing champion organisation committee of the Cubing championship,
30 which took place in August 2003 in Toronto Canada, according to which the main event was the users' competition on the classic Rubik cube, that is on cube No 3, whereas the

one on the cubes No 4 and No 5 was a secondary event. This is due to the problems that these cubes present during their speed Cubing.

The disadvantage of the slow rotation of these cubes' layers is due to the fact that apart from the planar and spherical surfaces, cylindrical surfaces coaxial with the axes of the three – dimensional rectangular Cartesian coordinate system have mainly been used for the configuration of the internal surfaces of the smaller pieces of the cubes' layers. However, although the use of these cylindrical surfaces could secure stability and fast rotation for the Rubik cube due to the small number of layers, $N=3$, per direction, when the number of layers increases there is a high probability of some smaller pieces being damaged or of the cube being dismantled, resulting to the disadvantage of slow rotation. This is due to the fact that the 4x4x4 and 5x5x5 cubes are actually manufactured by hanging pieces on the 2x2x2 and 3x3x3 cubes respectively. This way of manufacturing, though, increases the number of smaller pieces, having as a result the above-mentioned disadvantages of these cubes.

What constitutes the innovation and the improvement of the construction according to the present invention is that the configuration of the internal surfaces of each piece is made not only by the required planar and spherical surfaces that are concentric with the solid geometrical centre, but mainly by right conical surfaces. These conical surfaces are coaxial with the semi – axes of the three – dimensional rectangular Cartesian coordinate system, the number of which is k per semi – axis, and consequently $2k$ in each direction of the three dimensions.

Thus, when $N=2k$ even number, the resultant solid has N layers per direction visible to the toy user, plus one additional layer, the intermediate layer in each direction, that is not visible to the user, whereas when $N=2k+1$, odd number, then the resultant solid has N layers per direction, all visible to the toy user.

We claim that the advantages of the configuration of the internal surfaces of every smaller piece mainly by conical surfaces instead of cylindrical, which are secondarily used only in few cases, in combination with the necessary planar and spherical surfaces, are the following:

A) Every separate smaller piece of the toy consists of three discernible separate parts. The first one, substantially cubic in shape, lies towards the solid's surface, the intermediate second part, which has a conical sphenoid shape pointing substantially towards the geometric centre of the solid, its cross section being either in the shape of an equilateral spherical triangle or of an isosceles spherical trapezium or of any spherical quadrilateral, and its innermost third part, which is close to the solid geometric centre and is part of a

sphere or of a spherical shell, delimited appropriately by conical or planar surfaces or by cylindrical surfaces only when it comes to the six caps of the solid. It is obvious, that the upper cubic part is missing from the separate smaller pieces as it is spherically cut when these are not visible to the user.

5 **B)** The connection of the corner separate pieces of each cube with the solid interior, which is the most important problem to the construction of three – dimensional logic toys of that kind and of that shape, is ensured, so that these pieces are completely protected from dismantling.

10 **C)** With this configuration, each separate piece extends to the appropriate depth in the interior of the solid and it is protected from being dismantled, on the one hand by the six caps of the solid, that is the central separate pieces of each face, and on the other hand by the suitably created recesses – protrusions, whereby each separate piece is intercoupled and supported by its neighbouring pieces, said recesses-protrusions being such as to create, at the same time, general spherical recesses-protrusions between adjacent layers. These
15 recesses – protrusions both intercouple and support each separate piece with its neighbouring, securing, on the one hand, the stability of the construction and, on the other hand, guiding the pieces during the layers' rotation around the axes. The number of these recesses – protrusions could be more than 1 when the stability of the construction requires it, as shown in the drawings of the present invention.

20 **D)** Since the internal parts of the several separate pieces are conical and spherical, they can easily rotate in and above conical and spherical surfaces, which are surfaces made by rotation and consequently the advantage of the fast and unhindered rotation, reinforced by the appropriate rounding of the edges of each separate piece, is ensured.

25 **E)** The configuration of each separate piece's internal surfaces by planar spherical and conical surfaces is more easily made on the lathe.

F) Each separate piece is self-contained, rotating along with the other pieces of its layer around the corresponding axis in the way the user desires.

30 **G)** According to the way of manufacture suggested by the present invention, two different solids correspond to each value of k . The solid with $N=2k$, that is with an even number of visible layers per direction, and the solid with $N=2k+1$ with the next odd number of visible layers per direction. The only difference between these solids is that the intermediate layer of the first one is not visible to the user, whereas the intermediate layer of the second emerges at the toy surface. These two solids consist, as it is expected, of exactly the same number of separate pieces, that is $T=6N^2+3$, where N can only be an even number.

H) The great advantage of the configuration of the separate pieces internal surfaces of each solid with conical surfaces in combination with the required planar and spherical surfaces, is that whenever an additional conical surface is added to every semi – axis of the three – dimensional rectangular Cartesian coordinate system, then two new solids are produced, said solids having two more layers than the initial ones.

Thus, when $\kappa=1$, two cubes with $N=2\kappa=2 \times 1=2$ and $N=2\kappa +1=2 \times 1+1=3$ arise, that is the **cubic logic toys No2 and No3**, when $\kappa=2$, the cubes with $N=2\kappa=2 \times 2=4$ and $N=2\kappa+1=2 \times 2+1=5$ arise, that is the **cubic logic toys No4 and No5, e.t.c.** and, finally, when $\kappa=5$ the cubes $N=2\kappa=2 \times 5=10$ and $N=2\kappa+1=2 \times 5+1=11$ are produced, that is the **cubic logic toys No 10 and No 11**, where the present invention stops.

The fact that when a new conical surface is added two new solids are produced is a great advantage as it makes the invention unified.

As it can easily be calculated, the number of the possible different places that each cube's pieces can take, during rotation, increases spectacularly as the number of layers increases, but at the same time the difficulty in solving the cube increases.

The reason why the present invention finds application up to the cube $N=11$, as we have already mentioned, is due to the increasing difficulty in solving the cubes when more layers are added as well as due to geometrical constraints and practical reasons.

The geometrical constraints are the following:

a) According to the present invention, in order to divide the cube into equal N layers we have already proved that N should verify the inequality $\sqrt{2} (a/2-a/N) < a/2$. Having solved the inequality, it is obvious that the whole values of N are $N < 6,82$. This is possible when $N=2$, $N=3$, $N=4$, $N=5$ and $N=6$ and as a result the cubic logic toys No2, No3, No4, No5 and No6, whose shape is ideally cubic, are produced.

b) The constraint in the value of $N < 6,82$ can be overcome if the planar faces of the cube become spherical parts of long radius. Therefore, the final solid with $N=7$ and more layers loses the classical geometrical cubic shape, that with six planar surfaces, but from $N=7$ to $N=11$ the six solid faces are no longer planar but spherical, of long radius compared to the cube dimensions, the shape of said spherical surfaces being almost planar, as the rise of the solid faces from the ideal level, is about 5% of the side length of the ideal cube.

Although the shape of the resultant solids from $N=7$ to $N=11$ is substantially cubic, according to the Topology branch the circle and the square are exactly the same shapes and subsequently the classic cube continuously transformed to substantially cubic is the same

shape as the sphere. Therefore, we think that it is reasonable to name all the solids produced by the present invention **cubic logic toys No N**, as they are manufactured in exactly the same unified way, that is by using conical surfaces.

The practical reasons why the present invention finds application up to the cube N=11 are the following:

a) A cube with more layers than N=11 would be hard to rotate due to its size and the large number of its separate pieces.

b) When $N > 10$, the visible surfaces of the separate pieces that form the acmes of the cube lose their square shape and become rectangular. That's why the invention stops at the value N=11 for which the ratio of the sides b/a of the intermediate on the acmes rectangular is 1, 5.

Finally, we should mention that when N=6, the value is very close to the geometrical constraint $N < 6,82$. As a result, the intermediate sphenoid part of the separate pieces, especially of the corner ones, will be limited in dimensions and must be either strengthened or become bigger in size during construction. That is not the case if the cubic logic toy No 6 is manufactured in the way the cubic logic toys with $N \geq 7$ are, that is with its six faces consisting of spherical parts of long radius. That's why we suggest two different versions in manufacturing the cubic logic toy No6; version No6a is of a normal cubic shape and version No6b is with its faces consisting of spherical parts of long radius. The only difference between the two versions is in shape since they consist of exactly the same number of separate pieces.

This invention has been possible since the problem of connecting the corner cube piece with the solid interior has been solved, so that the said corner piece can be self-contained and rotate around any semi – axis of the three – dimensional rectangular Cartesian coordinate system, be protected during rotation by the six caps of the solid, that is the central pieces of each face, to secure that the cube is not dismantled.

I. This solution became possible based on the following observations:

a) The diagonal of each cube with side length a forms with the semi-axes OX, OY, OZ, of the three – dimensional rectangular Cartesian coordinate system angles equal to $\tan \omega = a\sqrt{2}/a$, $\tan \omega = \sqrt{2}$, therefore $\omega = 54,735610320^\circ$ (figure 1.1).

b) If we consider three right cones with apex to the beginning of the coordinates, said right cones having axes the positive semi – axes OX, OY, OZ, their generating line forming with the semi – axes OX, OY, OZ an angle $\varphi > \omega$, then the intersection of these three cones is a

sphenoid solid of continuously increasing thickness, said sphenoid solid's apex being located at the beginning of the coordinates (figure 1.2), of equilateral spherical triangle cross section (figure 1.3) when cut by a spherical surface whose centre coincides with the coordinates beginning. The length of the sides of the said spherical triangle increases as we
5 approach the cube apex. The centre- axis of the said sphenoid solid coincides with the diagonal of the cube.

The three side surfaces of that sphenoid solid are parts of the surfaces of the mentioned cones and, as a result, the said sphenoid solid can rotate in the internal surface of the corresponding cone, when the corresponding cone axis or the corresponding semi – axis of
10 the three – dimensional rectangular Cartesian coordinate system rotates.

Thus, if we consider that we have $1/8$ of a sphere with radius R , the centre of said sphere being located at the coordinates beginning, appropriately cut with planes parallel to the planes XY , YZ , ZX , as well as a small cubic piece, whose diagonal coincides with the initial cube diagonal (figure 1.4), then these three pieces (figure 1.5) embodied into a separate
15 piece give us the general form and the general shape of the corner pieces of all the present invention cubes (figure 1.6).

It is enough, therefore, to compare the figure 1.6 with the figures 2.1, 3.1, 4.1, 5.1, 6a.1, 6b.1 7.1, 8.1, 9.1, 10.1, 11.1, in order to find out the unified manufacturing way of the corner piece of each cube according to the present invention. In the above- mentioned
20 figures one can clearly see the three discernible parts of the corner pieces; the first part which is substantially cubic, the second part which is of a conical sphenoid shape and the third part which is a part of a sphere. Comparing the figures is enough to prove that the invention is unified although it finally produces more than one solids.

The other separate pieces are produced exactly the same way and their shape that depends
25 on the pieces' place in the final solid is alike. Their conical sphenoid part, for the configuration of which at least four conical surfaces are used, can have the same cross section all over its length or different cross-section per parts. Whatever the case, the shape of the cross-section of the said sphenoid part is either of an isosceles spherical trapezium or of any spherical quadrilateral. The configuration of this conical sphenoid part is such so as
30 to create on each separate piece the above-mentioned recesses-protrusions whereby each separate piece is intercoupled and supported by its neighbouring pieces. At the same time, the configuration of the conical sphenoid part in combination with the third lower part of the pieces creates general spherical recesses-protrusions between adjacent layers, securing the

stability of the construction and guiding the layers during rotation around the axes. Finally, the lower part of the separate pieces is a piece of a sphere or of spherical shell.

It should also be clarified that the angle φ_1 of the first cone k_1 should be greater than $54,73561032^\circ$ when the cone apex coincides with the coordinates beginning. However, if
5 the cone apex moves to the negative part of the semi – axis of rotation, then the angle φ_1 could be slightly less than $54,73561032^\circ$ and this is the case especially when the number of layers increases.

We should also note that the separate pieces of each cube are fixed on a central three – dimensional solid cross whose six legs are cylindrical and on which we screw the six caps
10 of each cube with the appropriate screws. The caps, that is the central separate pieces of each face, whether they are visible or not, are appropriately formed having a hole (figure 1.7) through which the support screw passes after being optionally surrounded with appropriate springs (figure 1.8). The way of supporting is similar to the support of the Rubik cube.

15 Finally, we should mention that after the support screw passes through the hole in the caps of the cubes, especially in the ones with an even number of layers, it is covered with a flat plastic piece fitted in the upper cubic part of the cap.

The present invention is fully understood by anyone who has a good knowledge of visual geometry. For that reason there is an analytic description of figures from 2 to 11
20 accompanying the present invention and proving that:

- a) The invention is a unified inventive body.
- b) The invention improves the up to date manufactured in several ways and by several inventor cubes, that is $2 \times 2 \times 2$, $4 \times 4 \times 4$ and $5 \times 5 \times 5$ cubes, which, however, present problems during their rotation.
- 25 c) The classic and functioning without problems Rubik cube, i.e. the $3 \times 3 \times 3$ cube, is included in that invention with some minor modifications.
- d) It expands for the first time worldwide, from what we know up to now, the logic toys series of substantially cubic shape up to the number No 11, i.e. the cube with 11 different layers per direction.

30 Finally, we should mention that, because of the absolute symmetry, the separate pieces of each cube form groups of similar pieces, the number of said groups depending on the number k of the conical surfaces per semi – axis of the cube, and said number being a triangle or triangular number. As it is already known, triangle or triangular numbers are the numbers that are the partial sums of the series $\Sigma=1 + 2 + 3 + 4 + \dots + v$, i.e. of the series the

difference between the successive terms of which is 1. In this case the general term of the series is $v=k+1$.

In figures 2 to 11 of the present invention one can easily see:

- a) The shape of all the different separate pieces each cube is consisted of.
- 5 b) The three discernible parts of each separate piece; the upper part which is substantially cubic, the intermediate second part which is of a conical sphenoid shape and the third part which is a part of a sphere or of a spherical shell.
- c) The above-mentioned recesses-protrusions on the different separate pieces whenever necessary.
- 10 d) The above-mentioned between adjacent layers general spherical recesses-protrusions, which secure the stability of construction and guide the layers during rotation around the axes.

II. Thus, when $k=1$ and $N=2k=2 \times 1=2$, i.e. for the **cubic logic toy No 2**, we have only (3) three different kinds of separate pieces. The corner piece 1 (figure 2.1) and in total eight
15 similar pieces, all visible to the toy user, the intermediate piece 2 (figure 2.2) and in total twelve similar pieces, all of non visible to the toy user and piece 3, the cap of the cube, and in total six similar pieces all non visible to the toy user. Finally, piece 4 is the non-visible central, three – dimensional solid cross that supports the cube (figure 2.4).

In figures 2.1.1, 2.2.1, 2.2.2 and 2.3.1 we can see the cross sections of these pieces.

20 In figure 2.5 we can see these three different kinds of pieces of the cube, placed at their position along with the non-visible central three – dimensional solid cross that supports the cube.

In figure 2.6 we can see the geometrical characteristics of the cubic logic toy No 2 where R generally represents the radiuses of concentric spherical surfaces that are necessary for the
25 configuration of the internal surfaces of the cube's separate pieces.

In figure 2.7 we can see the position of the separate central pieces of the intermediate non-visible layer in each direction on the non-visible central three – dimensional solid cross that supports the cube.

In figure 2.8 we can see the position of the separate pieces of the intermediate non-visible
30 layer in each direction on the non-visible central three – dimensional solid cross that supports the cube.

In figure 2.9 we can see the position of the separate pieces of the first layer in each direction on the non-visible central three – dimensional solid cross that supports the cube.

Finally, in figure 2.10 we can see the final shape of the cubic logic toy No 2. The cubic logic toy No 2 consists of twenty- seven (27) separate pieces in total along with the non-visible central three – dimensional solid cross that supports the cube.

III. When $\kappa=1$ and $N=2\kappa+1 = 2 \times 1 + 1 = 3$, i.e. **the cubic logic toy No 3**, we have again (3)

5 three kinds of different, separate pieces. The corner piece 1, (figure 3.1) and in total eight similar pieces, all visible to the toy user, the intermediate piece 2 (figure 3.2) and in total twelve similar pieces, all visible to the user, and finally piece 3, (figure 3.3) the cube cap, and in total six similar pieces, all visible to the toy user. Finally, the piece 4 is the non-visible central three – dimensional solid cross that supports the cube (figure 3.4).

10 In figures 3.1.1, 3.2.1, 3.2.2, 3.3.1 we can see the cross-sections of these different separate pieces by their symmetry planes.

In figure 3.5 we can see these three different pieces placed at their position along with the non-visible central three – dimensional solid cross that supports the cube.

In figure 3.6 we can see the geometrical characteristics of the cubic logic toy No 3.

15 In figure 3.7 we can see the internal face of the first layer along with the non-visible central three – dimensional solid cross that supports the cube.

In figure 3.8 we can see the face of the intermediate layer in each direction along with the non-visible central three – dimensional solid cross that supports the cube.

20 In figure 3.9 we can see the section of that intermediate layer by an intermediate symmetry plane of the cube.

Finally, in figure 3.10 we can see the final shape of the cubic logic toy No 3. The cubic logic toy No 3 consists of twenty- seven (27) separate pieces in total along with the non-visible central three – dimensional solid cross that supports the cube.

25 By comparing the figures of the cubic logic toys No 2 and No 3, it is clear that the non-visible intermediate layer of the toy No 2 becomes visible in the toy No 3 while both the cubes consist of the same total number of separate pieces. Besides, this has already been mentioned as one of the advantages of the present invention and it proves that it is unified. At this point, it is useful to compare the figures of the separate pieces of the cubic logic toy No 3 with the figures of the separate pieces of the Rubik cube.

30 The difference between the figures is that the conical sphenoid part of the separate pieces of this invention does not exist in the pieces of the Rubik cube. Therefore, if we remove that conic sphenoid part from the separate pieces of the cubic logic toy No 3, then the figures of that toy will be similar to the Rubik cube figures.

In fact, the number of layers $N=3$ is small and, as a result, the conical sphenoid part is not necessary, as we have already mentioned the Rubik cube does not present problems during its speed cubing. The construction, however, of the cubic logic toy No 3 in the way this invention suggests, has been made not to improve something about the operation of the Rubik cube but in order to prove that the invention is unified and sequent.

However, we think that the absence of that conical sphenoid part in the Rubik cube, which is the result of the mentioned conical surfaces introduced by the present invention, is the main reason why, up to now, several inventors could not conclude in a satisfactory and without operating problems way of manufacturing these logic toys.

Finally, we should mention that only for manufacturing reasons and for the easy assembling of the cubes when $N=2$ and $N=3$, the last but one sphere, i.e. the sphere with R_1 radius, shown in figures 2.6 and 3.6, could be optionally replaced by a cylinder of the same radius only for the configuration of the intermediate layer whether it is visible or not, without influencing the generality of the method.

IV. When $\kappa=2$ and $N=2\kappa=2 \times 2=4$, i.e. for the **cubic logic toy No 4**, there are (6) six different kinds of separate pieces. Piece 1, (figure 4.1) and in total eight similar pieces, all visible to the user, piece 2, (figure 4.2) and in total twenty four similar pieces, all visible to the user, piece 3, (figure 4.3) and in total twenty four similar pieces, all visible to the user, piece 4, (figure 4.4) and in total twelve similar pieces, all non-visible to the user, piece 5, (figure 4.5) and in total twenty four similar pieces, all non-visible to the user and piece 6, (figure 4.6), the cap of the cubic logic toy No 4, and in total six similar pieces, all non-visible to the user. Finally, in figure 4.7 we can see the non-visible central three – dimensional solid cross that supports the cube.

In figures 4.1.1, 4.2.1, 4.3.1, 4.4.1, 4.4.2, 4.5.1, 4.6.1 and 4.6.2 we can see the cross sections of these different separate pieces.

In figure 4.8 we can see at an axonometric projection these different pieces placed at their positions along with the non-visible central three – dimensional solid cross that supports the cube No 4.

In figure 4.9 we can see the intermediate non-visible layer in each direction along with the non-visible central three – dimensional solid cross that supports the cube.

In figure 4.10 we can see the section of the pieces of the intermediate non-visible layer by an intermediate symmetry plane of the cube, as well as the projection of the pieces of the second layer of the cube on the said intermediate layer.

In figure 4.11 we can see at an axonometric projection the non-visible intermediate layer and the supported on it, second layer of the cube.

In figure 4.12 we can see at an axonometric projection the first and the second layer along with the intermediate non-visible layer and the non-visible central three – dimensional solid cross that supports the cube.

In figure 4.13 we can see the final shape of the cubic logic toy No 4.

In figure 4.14 we can see the external face of the second layer with the intermediate non-visible layer and the non-visible central three – dimensional solid cross that supports the cube.

In figure 4.15 we can see the internal face of the first layer of the cube with the non-visible central three – dimensional solid cross that supports the cube.

Finally, in figure 4.16 we can see the geometrical characteristics of the cubic logic toy No 4, for the configuration of the internal surfaces of the separate pieces of which, two conical surfaces per semi - direction of the three – dimensional rectangular Cartesian coordinate system have been used. The cubic logic toy No 4 consists of ninety- nine (99) separate pieces in total along with the non-visible central three – dimensional solid cross that supports the cube.

V. When $\kappa=2$ and $N=2\kappa+1=2x2+1=5$, i.e. for the **cubic logic toy No 5**, there are again (6) six different kinds of separate pieces, all visible to the user. Piece 1, (figure 5.1) and in total eight similar pieces, piece 2, (figure 5.2) and in total twenty four similar pieces, piece 3, (figure 5.3) and in total twenty four similar pieces, piece 4, (figure 5.4) and in total twelve similar pieces, piece 5, (figure 5.5) and in total twenty four similar pieces, and piece 6, (figure 4.6) the cap of the cubic logic toy No 5 and in total six similar pieces. Finally, in figure 5.7 we can see the non-visible central three – dimensional solid cross that supports the cube.

In figures 5.1.1, 5.2.1, 5.3.1, 5.4.1, 5.4.2, 5.5.1, 5.6.1, 5.6.2 we can see the cross sections of these different separate pieces.

In figure 5.8 we can see the geometrical characteristics of the cubic logic toy No 5, for the configuration of the internal surfaces of the separate pieces of which, two conical surfaces per semi - direction of the three – dimensional rectangular Cartesian coordinate system have been used.

In figure 5.9 we can see at an axonometric projection these six different pieces placed at their position along with the non-visible central three – dimensional solid cross that supports the cube.

In figure 5.10 we can see the internal face of the first layer of the cubic logic toy No 5.

In figure 5.11 we can see the internal face of the second layer and in figure 5.14 its external face.

In figure 5.12 we can see the face of the intermediate layer of the cubic logic toy No 5 along
5 with the non-visible central three – dimensional solid cross that supports the cube.

In figure 5.13 we can see the section of the pieces of the intermediate layer of the cube No 5 and the section of the non-visible central three – dimensional solid cross that supports the cube by an intermediate symmetry plane of the cube.

In figure 5.15 we can see the first and the second layer with the non-visible central three –
10 dimensional solid cross that supports the cube.

In figure 5.16 we can see the first, the second and the intermediate layer with the non-visible central three – dimensional solid cross that supports the cube.

Finally, in figure 5.17 we can see the final shape of the cubic logic toy No 5.

The cubic logic toy No 5 consists of ninety- nine (99) separate pieces in total along with the
15 non-visible central three – dimensional solid cross that supports the cube, the same number of pieces as in the cubic logic toy No 4.

VI.a When $\kappa=3$, that is when we use three conical surfaces per semi axis of the three-
dimensional rectangular Cartesian coordinate system and $N= 2\kappa=2 \times 3=6$ that is for the **cubic
logic toy No 6a**, whose final shape is cubic, we have **(10)** different kinds of separate pieces,
20 of which only the first six are visible to the user, whereas the next four are not.

Piece **1** (figure 6a.1) and in total eight similar pieces, piece **2** (figure 6a.2) and in total
twenty-four similar pieces, piece **3** (figure 6a.3) and in total twenty-four similar pieces,
piece **4** (figure 6a.4) and in total twenty-four similar pieces, piece **5** (figure 6a.5) and in total
forty-eight similar pieces, piece **6** (figure 6a.6) and in total twenty-four similar pieces, up to
25 this point all visible to the user of the toy. The non- visible, different pieces that form the
intermediate non visible layer in each direction of the cubic logic toy No 6a are: piece **7**
(figure 6a.7) and in total twelve similar pieces, piece **8** (figure 6a.8) and in total twenty-four
similar pieces, piece **9** (figure 6a.9) and in total twenty-four similar pieces and piece **10**
(figure 6a.10) and in total six similar pieces, the caps of the cubic logic toy No 6a. Finally,
30 in figure 6a.11 we can see the non- visible central three-dimensional solid cross that
supports the cube No 6a.

In figure 6a.1.1. , 6a.2.1, 6a.3.1, 6a.4.1, 6a.5.1, 6a.6.1, 6a.7.1, 6a.7.2, 6a.8.1, 6a.9.1, 6a.10.1 and 6a.10.2 we can see the cross-sections of the ten separate, different pieces of the cubic logic toy No 6a.

5 In figure 6a.12 we can see these ten different pieces of the cubic logic toy No 6a, placed at their position along with the non visible central three-dimensional solid cross that supports the cube.

10 In figure 6a.13 we can see the geometrical characteristics of the cubic logic toy No 6a, where for the configuration of the internal surfaces of its separate pieces three conical surfaces have been used per semi direction of the three-dimensional rectangular Cartesian coordinate system.

In figure 6a.14 we can see the internal face of the first layer of the cubic logic toy No 6a along with the non visible central three-dimensional solid cross that supports the cube.

In figure 6a.15 we can see the internal face and in figure 6a.16 we can see the external face of the second layer of the cubic logic toy No 6a.

15 In figure 6a.17 we can see the internal face and in figure 6a.18 we can see the external face of the third layer of the cubic logic toy No 6a.

In figure 6a.19 we can see the face of the non- visible intermediate layer in each direction along with the non -visible central three-dimensional solid cross that supports the cube.

20 In figure 6a.20 we can see the sections of the separate pieces of the intermediate layer as well as of the non visible central three dimensional solid cross that supports the cube by an intermediate symmetry plane of the cube, and we can also see the projection of the separate pieces of the third layer on this plane, said third layer being supported on the intermediate layer of the cubic logic toy No 6a.

25 In figure 6a.21 we can see at an axonometric projection the first three layers that are visible to the user, as well as the intermediate non visible layer in each direction and the non visible central three-dimensional solid cross that supports the cube.

Finally, in figure 6a.22 we can see the final shape of the cubic logic toy No 6a.

The cubic logic toy No 6a consists of two hundred and nineteen (219) separate pieces in total along with the non- visible central three-dimensional solid cross that supports the cube.

30 **VI.b** When $\kappa=3$, that is when we use three conical surfaces per semi axis of the three-dimensional rectangular Cartesian coordinate system and $N= 2\kappa=2 \times 3=6$, that is for the **cubic logic toy No 6b**, whose final shape is substantially cubic, its faces consisting of

spherical surfaces of long radius, we have **(10)** different kinds of separate pieces, of which only the first six are visible to the user, whereas the next four are not.

Piece **1** (figure 6b.1) and in total eight similar pieces, piece **2** (figure 6b.2) and in total twenty-four similar pieces, piece **3** (figure 6b.3) and in total twenty-four similar pieces,
5 piece **4** (figure 6b.4) and in total twenty-four similar pieces, piece **5** (figure 6b.5) and in total forty eight similar pieces, piece **6** (figure 6b.6) and in total twenty-four similar pieces, up to this point all visible to the user. The non visible different pieces that form the intermediate non visible layer in each direction of the cubic logic toy No 6b are: piece **7** (figure 6b.7) and in total twelve similar pieces, piece **8** (figure 6b.8) and in total twenty-four similar pieces,
10 piece **9** (figure 6b.9) and in total twenty-four similar pieces and piece **10** (figure 6b.10) and in total six similar pieces, the caps of the cubic logic toy No 6b. Finally, in figure 6b.11 we can see the non-visible central three-dimensional solid cross that supports the cube No 6b.

In figure 6b.12 we can see the ten different pieces of the cubic logic toy No 6b, placed at their position along with the non visible central three-dimensional solid cross that supports
15 the cube.

In figure 6b.13 we can see the geometrical characteristics of the cubic logic toy No 6b, for the configuration of the internal surfaces of the separate pieces of which three conical surfaces have been used per semi direction of the three-dimensional rectangular Cartesian coordinate system.

20 In figure 6b.14 we can see the internal face of the first layer of the cubic logic toy No 6b along with the non visible central three-dimensional solid cross that supports the cube.

In figure 6b.15 we can see the internal face and in figure 6a.16 we can see the external face of the second layer of the cubic logic toy No 6b.

In figure 6b.17 we can see the internal face and in figure 6b.18 we can see the external face
25 of the third layer of the cubic logic toy No 6b.

In figure 6b.19 we can see the face of the non- visible intermediate layer in each direction along with the non- visible central three-dimensional solid cross that supports the cube.

In figure 6b.20 we can see the section of the separate pieces of the intermediate layer as well as of the non- visible central three- dimensional solid cross that supports the cube by an
30 intermediate symmetry plane of the cube.

In figure 6b.21 we can see at an axonometric projection the first three layers that are visible to the user, as well as the intermediate non -visible layer in each direction and the non visible central s three-dimensional solid cross that supports the cube.

Finally, in figure 6b.22 we can see the final shape of the cubic logic toy No 6b.

The cubic logic toy No 6b consists of two hundred and nineteen (219) separate pieces in total along with the non-visible central three-dimensional solid cross that supports the cube.

We have already mentioned that the only difference between the two versions of the cube No6 is in their final shape.

5 **VII.** When $\kappa=3$, that is when we use three conical surfaces per semi axis of the three-dimensional rectangular Cartesian coordinate system and $N=2\kappa+1=2\times 3+1=7$, that is for the **cubic logic toy No 7**, whose final shape is substantially cubic, its faces consisting of spherical surfaces of long radius, we have again **(10)** different kinds of separate pieces, which are all visible to the user of the toy.

10 Piece **1** (figure 7.1) and in total eight similar pieces, piece **2** (figure 7.2) and in total twenty-four similar pieces, piece **3** (figure 7.3) and in total twenty-four similar pieces, piece **4** (figure 7.4) and in total twenty-four similar pieces, piece **5** (figure 7.5) and in total forty eight similar pieces, piece **6** (figure 7.6) and in total twenty-four similar pieces, piece **7** (figure 7.7) and in total twelve similar pieces, piece **8** (figure 7.8) and in total twenty-four
15 similar pieces, piece **9** (figure 7.9) and in total twenty-four similar pieces and piece **10** (figure 7.10) and in total six similar pieces, the caps of the cubic logic toy No 7.

Finally, in figure 7.11 we can see the non- visible central three-dimensional solid cross that supports the cube No 7.

In figures 7.1.1, 7.2.1, 7.3.1, 7.4.1, 7.5.1, 7.6.1, 7.7.1, 7.7.2, 7.8.1, 7.9.1, 7.10.1 and 7.10.2
20 we can see the cross-sections of the ten different, separate pieces of the cubic logic toy No 7.

In figure 7.12 we can see the ten different pieces of the cubic logic toy No 7 placed at their position along with the non-visible central three-dimensional solid cross that supports the cube.

25 In figure 7.13 we can see the geometrical characteristics of the cubic logic toy No 7, for the configuration of the internal surfaces of the separate pieces of which three conical surfaces per semi direction of the three-dimensional rectangular Cartesian coordinate system have been used.

In figure 7.14 we can see the internal face of the first layer per semi direction of the cubic
30 logic toy No 7.

In figure 7.15 we can see the internal face of the second layer per semi direction along with the non -visible central three-dimensional solid cross that supports the cube and in figure 7.16 we can see the external face of this second layer.

In figure 7.17 we can see the internal face of the third layer per semi direction along with the non -visible central three-dimensional solid cross that supports the cube and in figure 7.18 we can see the external face of this third layer.

In figure 7.19 we can see the face of the intermediate layer in each direction along with the
5 central three-dimensional solid cross that supports the cube.

In figure 7.20 we can see the section of the separate pieces of the intermediate layer and of the non-visible central three-dimensional solid cross that supports the cube by an intermediate symmetry plane of the cube.

In figure 7.21 we can see at an axonometric projection the three first layers per semi
10 direction along with the intermediate layer in each direction, all of which are visible to the user of the toy along with the non- visible central three-dimensional solid cross, which supports the cube.

Finally, in figure 7.22 we can see the final shape of the cubic logic toy No 7.

The cubic logic toy No 7 consists of two hundred and nineteen (219) separate pieces in total
15 along with the non- visible central three-dimensional solid cross that supports the cube, i.e. the same number of pieces as in the cubic logic toy No 6.

VIII. When $\kappa=4$, that is when we use four conical surfaces per semi axis of the three-dimensional rectangular Cartesian coordinate system and $N= 2\kappa=2\times 4=8$, that is for the **cubic logic toy No 8** whose final shape is substantially cubic, its faces consisting of
20 spherical surfaces of long radius, we have **(15)** fifteen different kinds of separate smaller pieces, of which only the first ten are visible to the user of the toy whereas the next five are non visible. Piece 1 (figure 8.1) and in total eight similar pieces, piece 2 (figure 8.2) and in total twenty-four similar pieces, piece 3 (figure 8.3) and in total twenty-four similar pieces, piece 4 (figure 8.4) and in total twenty-four similar pieces, piece 5 (figure 8.5) and in total
25 forty-eight similar pieces, piece 6 (figure 8.6) and in total twenty-four similar pieces, piece 7 (figure 8.7) and in total twenty-four similar pieces, piece 8 (figure 8.8) and in total forty-eight similar pieces, piece 9 (figure 8.9) and in total forty- eight similar pieces and piece 10 (figure 8.10) and in total twenty-four similar pieces, all of which are visible to the user of the toy.

30 The non visible different pieces that form the intermediate non visible layer in each direction of the cubic logic toy No 8 are: piece 11 (figure 8.11) and in total twelve similar pieces, piece 12 (figure (8.12) and in total twenty-four similar pieces, piece 13 (figure 8.13) and in total twenty-four similar pieces, piece 14 (figure 8.14) and in total twenty-four similar pieces and piece 15 (figure 8.15) and in total six similar pieces, the caps of the cubic

logic toy No 8. Finally, in figure 8.16 we can see the non -visible central three-dimensional solid cross that supports the cube No 8.

In figures 8.1.1, 8.2.1, 8.3.1, 8.4.1, 8.5.1, 8.6.1, 8.7.1, 8.9.1, 8.10.1, 8.11.1, 8.11.2, 8.12.1, 8.13.1, 8.14.1 and 8.15.1 we can see the cross-sections of the fifteen different, separate
5 pieces of the cubic logic toy No 8.

In figure 8.17 we can see these fifteen separate pieces of the cubic logic toy No 8 placed at their position along with the non -visible central three-dimensional solid cross that supports the cube.

In figure 8.18 we can see the geometrical characteristics of the cubic logic toy No 8 for the
10 configuration of the internal surfaces of the separate pieces of which four conical surfaces per semi direction of the three-dimensional rectangular Cartesian coordinate system have been used.

In figure 8.19 we can see the section of the separate pieces of the intermediate non visible layer per semi direction and of the central three-dimensional solid cross by an intermediate
15 symmetry plane of the cube as well as the projection of the separate pieces of the fourth layer of each semi direction on this plane, said fourth layer being supported on the intermediate layer of this direction of the cubic logic toy No 8.

In figure 8.20 we can see the internal face of the first layer per semi direction of the cubic logic toy No 8 along with the non- visible central three-dimensional solid cross that supports
20 the cube.

In figure 8.21 we can see the internal face and in figure 8.21.1 we can see the external face of the second layer per semi direction of the cubic logic toy No 8.

In figure 8.22 we can see the internal face and in figure 8.22.1 we can see the external face of the third layer per semi direction of the cubic logic toy No 8.

25 In figure 8.23 we can see the internal face and in figure 8.23.1 we can see the external face of the fourth layer per semi direction of the cubic logic toy No 8.

In figure 8.24 we can see the face of the non- visible intermediate layer in each direction along with the non- visible central three-dimensional solid cross that supports the cube.

In figure 8.25 we can see at an axonometric projection the four visible layers of each semi
30 direction along with the non -visible intermediate layer of that direction and along with the non- visible central three-dimensional solid cross that supports the cube.

Finally, in figure 8.26 we can see the final shape of the cubic logic toy No 8.

The cubic logic toy No 8 consists of three hundred and eighty eight (387) pieces in total along with the non -visible central three-dimensional solid cross that supports the cube.

IX. When $\kappa=4$, that is when we use four conical surfaces per semi axis of the three-dimensional rectangular Cartesian coordinate system and $N=2\kappa+1=2 \times 4+1=9$, that is for the **cubic logic toy No 9** whose final shape is substantially cubic, its faces consisting of spherical surfaces of long radius, we have again (15) fifteen different and separate kinds of smaller pieces, all visible to the user of the toy. Piece 1 (figure 9.1) and in total eight similar pieces, piece 2 (figure 9.2) and in total twenty-four similar pieces, piece 3 (figure 9.3) and in total twenty-four similar pieces, piece 4 (figure 9.4) and in total twenty-four similar pieces, piece 5 (figure 9.5) and in total forty eight similar pieces, piece 6 (figure 9.6) and in total twenty-four similar pieces, piece 7 (figure 9.7) and in total twenty-four similar pieces, piece 8 (figure 9.8) and in total forty eight similar pieces, piece 9 (figure 9.9) and in total forty eight similar pieces and piece 10 (figure (9.10) and in total twenty-four similar pieces, piece 11 (figure 9.11) and in total twelve similar pieces, piece 12 (figure 9.12) and in total twenty-four similar pieces, piece 13 (figure 9.13) and in total twenty-four similar pieces, piece 14 (figure 9.14) and in total twenty-four similar pieces and finally, piece 15 (figure 9.15) and in total six similar pieces, the caps of the cubic logic toy No 9. Finally, in figure 9.16 we can see the non-visible central three-dimensional solid cross that supports the cube No 9.

In figures 9.1.1, 9.2.1, 9.3.1, 9.4.1, 9.5.1, 9.6.1, 9.7.1, 9.8.1, 9.9.1, 9.10.1, 9.11.1, 9.11.2, 9.12.1, 9.13.1, 9.14.1 and 9.15.1 we can see the cross-sections of the fifteen different, separate pieces of the cubic logic toy No 9.

In figure 9.17 we can see these separate fifteen pieces of the cubic logic toy No 9, placed at their position along with the non- visible central three-dimensional solid cross that supports the cube.

In figure 9.18 we can see the geometrical characteristics of the cubic logic toy No 9 for the configuration of the internal surfaces of the separate pieces of which four conical surfaces per semi direction of the three-dimensional rectangular Cartesian coordinate system have been used.

In figure 9.19 we can see the internal face of the first layer per semi direction of the cubic logic toy No 9 along with the non -visible central three-orthogonal solid cross that supports the cube.

In figure 9.20 we can see the internal face and in figure 9.20.1 the external face of the second layer per semi direction of the cubic logic toy No 9.

In figure 9.21 we can see the internal face and in figure 9.21.1 the external face of the third layer per semi direction of the cubic logic toy No 9.

In figure 9.22 we can see the internal face and in figure 9.22.1 the external face of the fourth layer per semi direction of the cubic logic toy No 9.

In figure 9.23 we can see the internal face of the intermediate layer in each direction of the cubic logic toy No 9 along with the non -visible central three-dimensional solid cross that supports the cube.

In figure 9.24 we can see the section of the separate pieces of the intermediate layer in each direction as well as of the non -visible central three-dimensional solid cross that supports the cube by an intermediate symmetry plane of the cubic logic toy No 9.

In figure 9.25 we can see at an axonometric projection the four layers in each semi direction along with the fifth intermediate layer of this direction and the non visible central three-dimensional solid cross that supports the cube.

Finally, in figure 9.26 we can see the final shape of the cubic logic toy No 9.

The cubic logic toy No 9 consists of three hundred and eighty eight (387) separate pieces in total along with the non -visible central three-dimensional solid cross that supports the cube, the same number of pieces as in the cubic logic toy No 8.

X. When $\kappa=5$, that is when we use five conical surfaces per semi axis of the three-dimensional rectangular Cartesian coordinate system and $N= 2\kappa=2 \times 5=10$, that is for the **cubic logic toy No 10** whose final shape is substantially cubic, its faces consisting of spherical surfaces of long radius, we have (21) twenty one different kinds of smaller pieces, of which only the first fifteen are visible to the user of the toy, whereas the next six are non visible.

Piece 1 (figure 10.1) and in total eight similar pieces, piece 2 (figure 10.2) and in total twenty-four similar pieces, piece 3 (figure 10.3) and in total twenty-four similar pieces, piece 4 (figure 10.4) and in total twenty-four similar pieces, piece 5 (figure 10.5) and in total forty eight similar pieces, piece 6 (figure 10.6) and in total twenty-four similar pieces, piece 7 (figure 10.7) and in total twenty-four similar pieces, piece 8 (figure 10.8) and in total forty eight similar pieces, piece 9 (figure 10.9) and in total forty eight similar pieces and piece 10 (figure 10.10) and in total twenty-four similar pieces, piece 11 (figure 10.11) and in total twenty-four similar pieces, piece 12 (figure 10.12) and in total forty eight similar pieces, piece 13 (figure 10.13) and in total forty eight similar pieces, piece 14 (figure 10.14) and in total forty eight similar pieces, piece 15 (figure 10.15) and in total twenty-four similar pieces, up to this point all visible to the user of the toy. The non visible different pieces that form the intermediate non visible layer in each direction of the cubic logic toy No 10 are: piece 16 (figure 10.16) and in total twelve similar pieces, piece 17 (figure 10.17) and in total

twenty-four similar pieces, piece 18 (figure 10.18) and in total twenty-four similar pieces, piece 19 (figure 10.19) and in total twenty-four similar pieces, piece 20 (figure 10.20) and in total twenty-four similar pieces, and, piece 21 (figure 10.21) and in total six similar pieces, the caps that of the cubic logic toy No 10.

5 Finally, in figure 10.22 we can see the non -visible central three-orthogonal solid cross that supports the cube No 10.

In figures 10.1.1, 10.2.1, 10.3.1, 10.4.1, 10.5.1, 10.6.1, 10.7.1, 10.8.1, 10.9.1, 10.10.1, 10.11.1, 10.12.1, 10.13.1, 10.14.1, 10.15.1, 10.16.1, 10.16.2, 10.17.1, 10.18.1, 10.19.1, 10.20.1 and 10.21.1 we can see the cross-sections of the twenty-one different separate

10 pieces of the cubic logic toy No 10.

In figure 10.23 we can see these twenty-one separate pieces of the cubic logic toy No 10 placed at their position along with the non- visible central three-dimensional solid cross that supports the cube.

15 In figure 10.24 we can see the internal face of the first layer in each semi direction of the cubic logic toy No 10 along with the non- visible central three-dimensional solid cross that supports the cube.

In figure 10.25 we can see the internal face and in figure 10.25.1 we can see the external face of the second layer per semi direction of the cubic logic toy No 10.

20 In figure 10.26 we can see the internal face and in figure 10.26.1 we can see the external face of the third layer per semi direction of the cubic logic toy No 10.

In figure 10.27 we can see the internal face and in figure 10.27.1 we can see the external face of the fourth layer per semi direction of the cubic logic toy No 10.

In figure 10.28 we can see the internal face and in figure 10.28.1 we can see the external face of the fifth layer per semi direction of the cubic logic toy No 10.

25 In figure 10.29 we can see the face of the non -visible intermediate layer in each direction along with the non- visible central three-dimensional solid cross that supports the cube.

30 In figure 10.30 we can see the internal face of the intermediate layer in each direction and the internal face of the fifth layer per semi direction said fifth layer being supported on the intermediate layer, along with the non visible central three-dimensional solid cross that supports the cube.

In figure 10.31 we can see the section of the separate pieces of the intermediate layer in each direction and of the central non visible three-dimensional solid cross by an intermediate symmetry plane of the cube as well as the projection on it of the separate pieces of the fifth layer of this semi direction.

In figure 10.32 we can see the geometrical characteristics of the cubic logic toy No 10 for the configuration of the internal surfaces of the separate pieces of which, five conical surfaces per semi direction of the three-dimensional rectangular Cartesian coordinate system have been used.

5 In figure 10.33 we can see at an axonometric projection, the five visible layers per semi direction along with the non-visible central three-dimensional solid cross that supports the cube.

Finally, in figure 10.34 we can see the final shape of the cubic logic toy No 10.

10 The cubic logic toy No 10 consists of six hundred and three (603) separate pieces in total along with the non- visible central three-dimensional solid cross that supports the cube.

XI. When $\kappa=5$, that is when we use five conical surfaces per semi axis of the three-dimensional rectangular Cartesian coordinate system and $N=2\kappa+1=2 \times 5+1=11$, that is for the **cubic logic toy No 11** whose final shape is substantially cubic its faces consisting of spherical surfaces of long radius, we have again (21) twenty-one different kinds of smaller
15 pieces, all visible to the user of the toy.

Piece **1** (figure 11.1) and in total eight similar pieces, piece **2** (figure 11.2) and in total twenty-four similar pieces, piece **3** (figure 11.3) and in total twenty-four similar pieces, piece **4** (figure 11.4) and in total twenty-four similar pieces, piece **5** (figure 11.5) and in total forty eight similar pieces, piece **6** (figure 11.6) and in total twenty-four similar pieces, piece
20 **7** (figure 11.7) and in total twenty-four similar pieces, piece **8** (figure 11.8) and in total forty eight similar pieces, piece **9** (figure 11.9) and in total forty eight similar pieces, piece **10** (figure (11.10) and in total twenty-four similar pieces, piece **11** (figure 11.11) and in total twenty-four similar pieces, piece **12** (figure (11.12) and in total forty eight similar pieces, piece **13** (figure 11.13) and in total forty eight similar pieces, piece **14** (figure 11.14) and in
25 total forty eight similar pieces, piece **15** (figure 11.15) and in total twenty-four similar pieces, piece **16** (figure 11.16) and in total twelve similar pieces, piece **17** (figure 11.17) and in total twenty-four similar pieces, piece **18** (figure 11.18) and in total twenty-four similar pieces, piece **19** (figure 11.19) and in total twenty-four similar pieces, piece **20** (figure 11.20) and in total twenty-four similar pieces, and piece **21** (figure 11.21) and in
30 total six similar pieces, the caps of the cubic logic toy No 11. Finally, in figure 11.22 we can see the non- visible central three-dimensional solid cross that supports the cube No 11.

In figures 11.1.1, 11.2.1, 11.3.1, 11.4.1, 11.5.1, 11.6.1, 11.7.1, 11.8.1, 11.9.1, 11.10.1, 11.11.1, 11.12.1, 11.13.1, 11.14.1, 11.15.1, 11.16.1, 11.16.2, 11.17.1, 11.18.1, 11.19.1,

11.20.1 and 11.21.1 we can see the cross- sections of the twenty-one different separate pieces of the cubic logic toy No 11.

In figure 11.23 we can see these twenty-one separate pieces of the cubic logic toy No 11 placed at their position along with the non-visible central three-dimensional solid cross that supports the cube.

In figure 11.24 we can see the internal face of the first layer per semi direction of the cubic logic toy No 11 along with the non- visible central three-dimensional solid cross that supports the cube.

In figure 11.25 we can see the internal face and in figure 11.25.1 we can see the external face of the second layer per semi direction of the three-dimensional rectangular Cartesian coordinate system of the cubic logic toy No 11.

In figure 11.26 we can see the internal face and in figure 11.26.1 we can see the external face of the third layer per semi direction of the three-dimensional rectangular Cartesian coordinate system of the cubic logic toy No 11.

In figure 11.27 we can see the internal face and in figure 11.27.1 we can see the external face of the fourth layer per semi direction of the three-dimensional rectangular Cartesian coordinate system of the cubic logic toy No 11.

In figure 11.28 we can see the internal face and in figure 11.28.1 we can see the external face of the fifth layer per semi direction of the three-dimensional rectangular Cartesian coordinate system of the cubic logic toy No 11.

In figure 11.29 we can see the intermediate layer per direction along with the non -visible central three-dimensional solid cross that supports the cube.

In figure 11.30 we can see the section of the separate pieces of the intermediate layer per direction along with the non -visible central three-dimensional solid cross that supports the cube by an intermediate symmetry plane of the cube No 11.

In figure 11.31 we can see the geometrical characteristics of the cubic logic toy No 11 for the configuration of the internal surfaces of the separate pieces of which five conical surfaces per semi direction of the three-dimensional rectangular Cartesian coordinate system have been used.

In figure 11.32 we can see at an axonometric projection, the five layers in each semi direction and the sixth layer in each direction, as well as the intermediate layer along with the non- visible central three-dimensional solid cross that supports the cube.

Finally, in figure 11.33 we can see the final shape of the cubic logic toy No 11.

The cubic logic toy No 11 consists of six hundred and three (603) separate pieces in total along with the non- visible central three-dimensional solid cross that supports the cube, the same number of pieces as in the cubic logic toy 10.

5 It is suggested that the construction material for the solid parts can be mainly plastic of good quality, while for $N=10$ and $N=11$ it could be replaced by aluminum.

Finally, we should mention that up to cubic logic toy No 7 we do not expect to face problems of wear of the separate pieces due to speed cubing.

10 The possible wear problems of the corner pieces, which are mainly worn out the most during speed cubing, for the cubes No 8 to No 11, can be dealt with, if during the construction of the corner pieces, their conical sphenoid parts are reinforced with a suitable metal bar, which will follow the direction of the cube's diagonal. This bar will start from the lower spherical part, along the diagonal of the cube and it will stop at the highest cubic part of the corner pieces.

15 Additionally, possible problems due to speed cubing for the cubes No 8 to No 11 may arise only because of the large number of the separate parts that these cubes are consisting of, said parts being 387 for the cubes No 8 and No 9, and 603 for the cubes No 10. These problems can only be dealt with by constructing the cubes in a very cautious way.

CLAIMS

1. A **cubic logic toy** which has the shape of a normal geometric solid, substantially cubic, which has N layers per each direction of the three-dimensional, rectangular Cartesian coordinate system, whose centre coincides with the geometric centre of the solid, said layers consisting of smaller separate pieces, the sides of said pieces which form part of the solid's external surface being substantially planar, said pieces being able to rotate in layers around the rectangular coordinate axes which pass through the centre of the solid's external surfaces and are vertical to said external surfaces, the visible surfaces of said pieces being coloured or bearing shapes or letters or numbers, **said cubic logic toy being characterised by the fact that:**
- for the configuration of the internal surfaces of all the separate smaller pieces of the solid, apart from the required planar surfaces and the required concentric spherical surfaces whose centre coincides with the geometric centre of the solid, a minimum number of κ right conical surfaces per semi-axis of said Cartesian coordinate system are used, the axis of said right conical surfaces coinciding with the corresponding semi-axis of said Cartesian coordinate system
- and for the first and innermost conical surface, if its apex coincides with the solid's geometric centre, the generating angle φ_1 is greater than $54,73561032^\circ$ and if its apex moves to the negative part of the semi-axes the generating angle can be slightly less than $54,73561032^\circ$, whereas for the following conical surfaces their generating angles are gradually increased, $\varphi_\kappa > \varphi_{\kappa-1} > \dots > \varphi_1$, so that when $N=2\kappa$ the resultant solid has an even number of N visible to the user layers per direction, plus one additional layer, the intermediate layer in each direction, which is not visible to the toy user, whereas when $N=2\kappa+1$, then the resultant solid has an odd number of N layers per direction, all visible to the toy user,
- the use of said conical surfaces constituting the innovation and the improvement in this toy construction, and resulting in the fact that all the smaller separate pieces which form the final solid are self-contained, extend to the appropriate depth in the interior of the solid, depending on their position and the layer they belong to, each of said pieces consisting of three discernible separate parts of which
- the first part, which lies towards the solid's surface is substantially cubic and is spherically cut when it is not visible to the user, the intermediate second part has a conical sphenoid shape, pointing substantially towards the geometric centre of the solid, its cross-section, when sectioned by spheres concentric with the geometric centre of the solid, being either

similar in shape along the entire length of said conical sphenoid part, or different from part to part of its length, said cross-sections' shape, however, being either that of an equilateral spherical triangle or that of an isosceles spherical trapezium or that of a spherical quadrilateral or, more precisely, that of any triangle or trapezium or quadrilateral on a sphere, the faces of said intermediate conical sphenoid part being delimited either by conical or spherical or planar surfaces, and the innermost third part of each piece is a part of a sphere or of a spherical shell delimited appropriately by planar and conical surfaces, said third part being delimited by a cylindrical surface only when it comes to the six caps of the solid, the shaping of said smaller separate pieces being such as to create on them recesses – protrusions, whereby each piece is intercoupled and supported by its neighbouring pieces, said recesses – protrusions being such as to create, at the same time, general spherical recesses - protrusions between adjacent layers, the maximum number of said spherical recesses - protrusions being two, when the stability of the construction requires it, in this latter case the number of the concentric spherical surfaces as well as of the conical surfaces being increased as necessary, said recesses – protrusions on the one hand protecting the separate pieces and the layers from being dismantled, and on the other hand guiding said pieces and layers during rotation, the edges of each of the said separate pieces, whether linear or curved, having been appropriately rounded, all the separate pieces which form the solid are held together by the six caps of the solid, i.e. the central pieces of each face of the final solid, said caps being either non-visible or visible to the user, each cap having a suitable cylindrical hole, coaxial with the semi-axes of the Cartesian coordinate system, one supporting screw, optionally surrounded by a suitable spring, passing through each of said cylindrical holes, said holes, when the cap is visible to the user, being covered with a flat plastic piece after being steadily screwed to the corresponding cylindrical legs of the non-visible central three-dimensional solid supporting cross, said cross supporting the cube and being located at the centre of the logic toy's solid

2. The cubic logic toy, according to claim 1, said toy's final solid having a cubic shape, with $N=2$ visible layers per direction plus one more layer, the intermediate layer per direction, non-visible to the user, said toy

being characterised by the fact that

for the configuration of the internal surfaces of its smaller separate pieces, apart from the required planar and spherical surfaces, one cone ($\kappa=1$) per semi-axis of the aforementioned three-dimensional, rectangular, Cartesian coordinate system is used, said toy consisting, apart from the non-visible, central, three-dimensional solid supporting cross, of twenty six

(26) more separate pieces, eight (8) of which are visible, whereas the other eighteen (18) are non-visible to the user.

3. The cubic logic toy, according to claim 1, said toy's final solid having a cubic shape, with $N=3$ visible layers per direction, said toy

5 being characterised by the fact that

for the configuration of the internal surfaces of its smaller, separate pieces, apart from the required planar and spherical surfaces, one cone ($\kappa=1$) per semi-axis of the aforementioned three-dimensional, rectangular, Cartesian coordinate system is used, said toy consisting, apart from the non-visible, central, three-dimensional solid supporting cross, of twenty six

10 (26) more separate pieces, which are all visible to the toy user.

4. The cubic logic toy, according to claim 1, said toy's final solid having a cubic shape, with $N=4$ visible layers per direction, plus one more layer, the intermediate layer per direction, non-visible to the user, said toy

being characterised by the fact that

15 for the configuration of the internal surfaces of its smaller, separate pieces, apart from the required planar and spherical surfaces, two cones ($\kappa=2$) per semi-axis of the aforementioned three-dimensional, rectangular, Cartesian coordinate system are used, said toy consisting, apart from the non-visible, central, three-dimensional solid supporting cross, of ninety eight (98) more separate pieces, fifty six (56) of which are visible, whereas the other forty two (42) are non-visible to the user.

5. The cubic logic toy, according to claim 1, said toy's final solid having a cubic shape, with $N=5$ visible layers per direction, said toy

being characterised by the fact that

25 for the configuration of the internal surfaces of its smaller, separate pieces, apart from the required planar and spherical surfaces, two cones ($k=2$) per semi-axis of the aforementioned three-dimensional, rectangular, Cartesian coordinate system are used, said toy consisting, apart from the non-visible, central, three-dimensional solid supporting cross, of ninety eight (98) more separate pieces, which are all visible to the toy user.

6. The cubic logic toy, according to claim 1, said toy's final solid having a cubic shape, with $N=6$ visible layers per direction plus one more layer, the intermediate layer per direction, which is not visible to the user, said toy

being characterized by the fact that

for the configuration of the internal surfaces of its smaller separate pieces, apart from the required planar and spherical surfaces, three cones ($k=3$) per semi-axis of the

aforementioned three-dimensional, rectangular, Cartesian coordinate system are used, said toy consisting, apart from the non-visible, central, three-dimensional solid supporting cross, of two hundred and eighteen (218) more separate pieces, a hundred and fifty two (152) of which are visible, whereas the other sixty six (66) pieces are non-visible to the toy user.

5 **7. The cubic logic toy**, according to claim 1, said toy's final solid having a **substantially** cubic shape, its faces consisting of parts of spherical surfaces of long radius, with $N=6$ visible layers per direction plus one more layer, the intermediate layer per direction, which is non-visible to the user, said toy

being characterized by the fact that

10 for the configuration of the internal surfaces of its smaller separate pieces, apart from the required planar and spherical surfaces, three cones ($\kappa = 3$) per semi-axis of the aforementioned three-dimensional, rectangular, Cartesian coordinate system are used, said toy consisting, apart from the non-visible, central, three-dimensional solid supporting cross, of two hundred and eighteen (218) more separate pieces, a hundred and fifty two (152) of which are visible, whereas the other sixty six (66) pieces are non-visible to the toy user.

15 **8. The cubic logic toy**, according to claim 1, said toy's final solid having a **substantially** cubic shape, its faces consisting of parts of spherical surfaces of long radius, with $N=7$ visible layers per direction, said toy

being characterized by the fact that

20 for the configuration of the internal surfaces of its smaller separate pieces, apart from the required planar and spherical surfaces, three cones ($\kappa = 3$) per semi-axis of the aforementioned three-dimensional, rectangular, Cartesian coordinate system are used, said toy consisting, apart from the non-visible, central, three-dimensional solid supporting cross, of two hundred and eighteen (218) more pieces, which are all visible to the toy user.

25 **9. The cubic logic toy**, according to claim 1, said toy's final solid having a **substantially** cubic shape, its faces consisting of parts of spherical surfaces of long radius, with $N=8$ visible layers per direction, plus one more layer, the intermediate layer per direction, which is non-visible to the user, said toy

being characterized by the fact that

30 for the configuration of the internal surfaces of its smaller, separate pieces, apart from the required planar and spherical surfaces, four cones ($\kappa = 4$) per semi-axis of the aforementioned three-dimensional, rectangular, Cartesian coordinate system are used, said toy consisting, apart from the non-visible, central, three-dimensional solid supporting cross,

of three hundred and eighty six (386) more pieces, two hundred and ninety six (296) of which are visible, whereas the other ninety (90) pieces are non-visible to the toy user.

10. The cubic logic toy, according to claim 1, said toy's final solid having a **substantially** cubic shape, its faces consisting of parts of spherical surfaces of long radius, with $N=9$

5 visible layers per direction, said toy

being characterized by the fact that

for the configuration of the internal surfaces of its smaller, separate pieces, apart from the required planar and spherical surfaces, four cones ($\kappa = 4$) per semi-axis of the aforementioned three-dimensional, rectangular, Cartesian coordinate system are used, said
10 toy consisting, apart from the non-visible, central, three-dimensional solid supporting cross, of three hundred and eighty six (386) more pieces, which are all visible to the toy user.

11. The cubic logic toy, according to claim 1, said toy's final solid having a **substantially** cubic shape, its faces consisting of parts of spherical surfaces of long radius, with $N=10$ visible layers per direction, plus one more layer, the intermediate layer per direction, which

15 is non-visible to the user, said toy

being characterized by the fact that

for the configuration of the internal surfaces of its smaller separate pieces, apart from the required planar and spherical surfaces, five cones ($\kappa = 5$) per semi-axis of the aforementioned three-dimensional, rectangular, Cartesian coordinate system are used, said
20 toy consisting, apart from the non-visible, central, three-dimensional solid supporting cross, of six hundred and two (602) pieces, four hundred and eighty eight (488) of which are visible, whereas the other one hundred and fourteen (114) pieces are non-visible to the toy user.

12. The cubic logic toy, according to claim 1, said toy's final solid having a **substantially**
25 cubic shape, its faces consisting of parts of spherical surfaces of long radius, with $N=11$ visible layers per direction, said toy

being characterized by the fact that

for the configuration of the internal surfaces of its smaller separate pieces, apart from the required planar and spherical surfaces, five cones ($\kappa = 5$) per semi-axis of the
30 aforementioned three-dimensional, rectangular, Cartesian coordinate system are used, said toy consisting, apart from the non-visible, central, three-dimensional solid supporting cross, of six hundred and two (602) more separate pieces, which are all visible to the toy user.

FIGURE 1

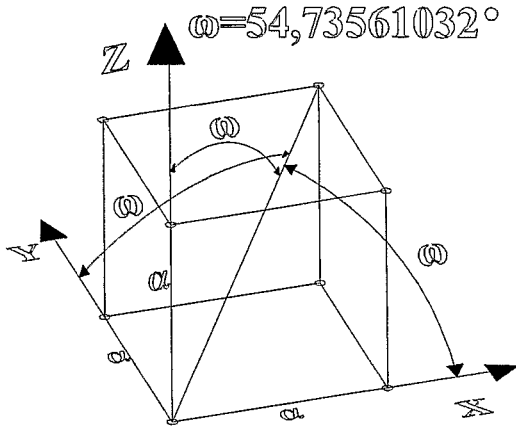

Fig.1.1

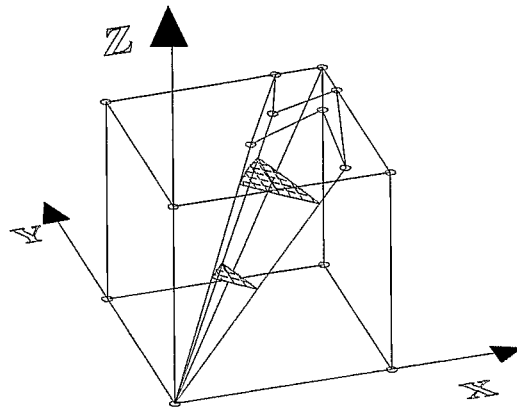

Fig.1.2



Fig.1.3

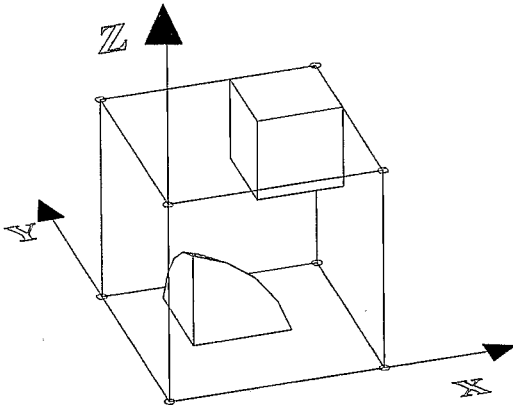

Fig.1.4

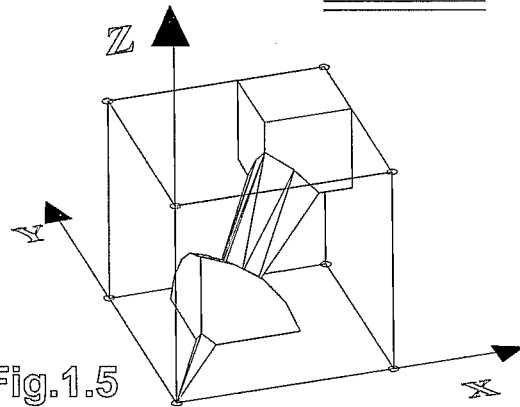

Fig.1.5

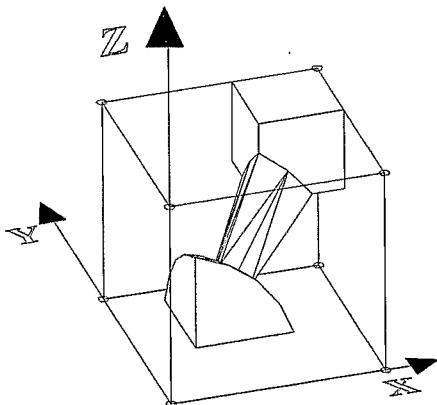

Fig.1.6



Fig.1.8

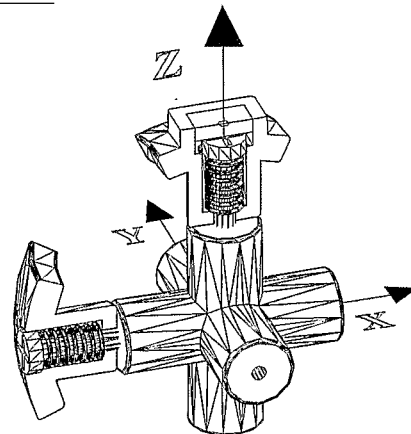

Fig.1.7

FIGURE 2

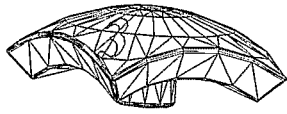

Fig.2.3

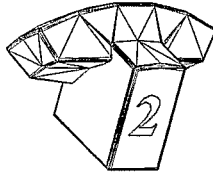

Fig.2.2

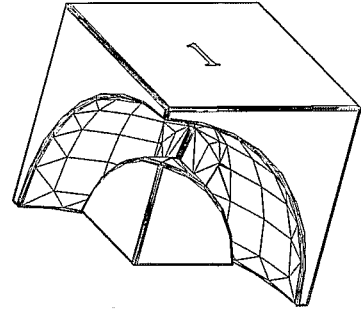

Fig.2.1

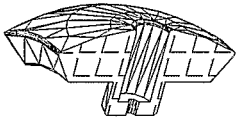

Fig.2.3.1

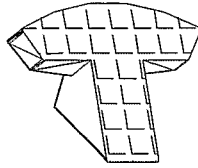

Fig.2.2.1

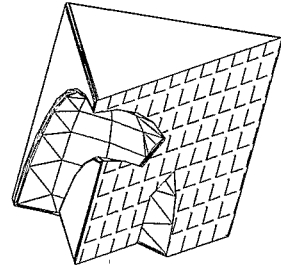

Fig.2.1.1

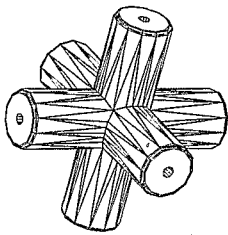

Fig.2.4

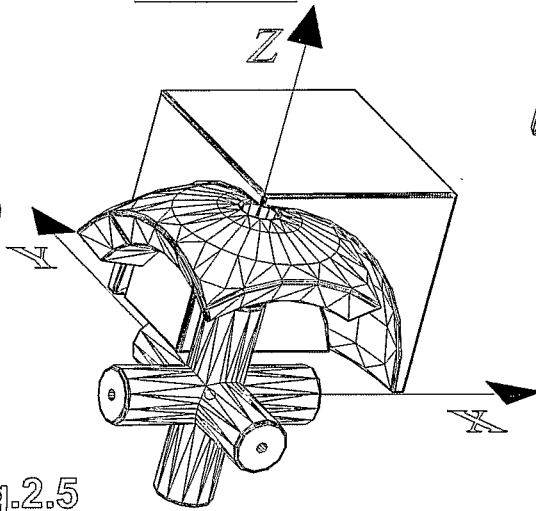

Fig.2.5

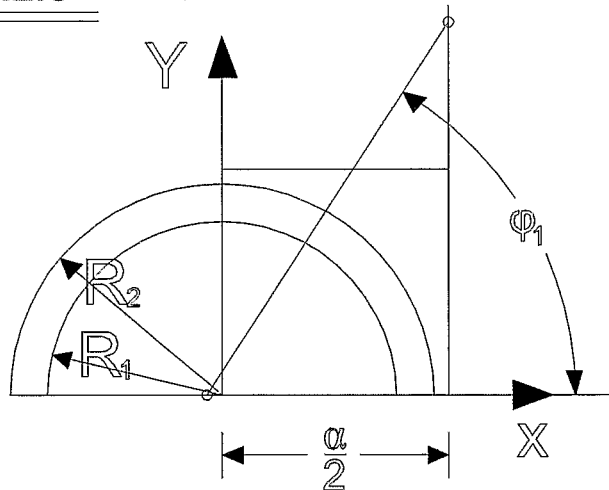

Fig.2.6

FIGURE 2

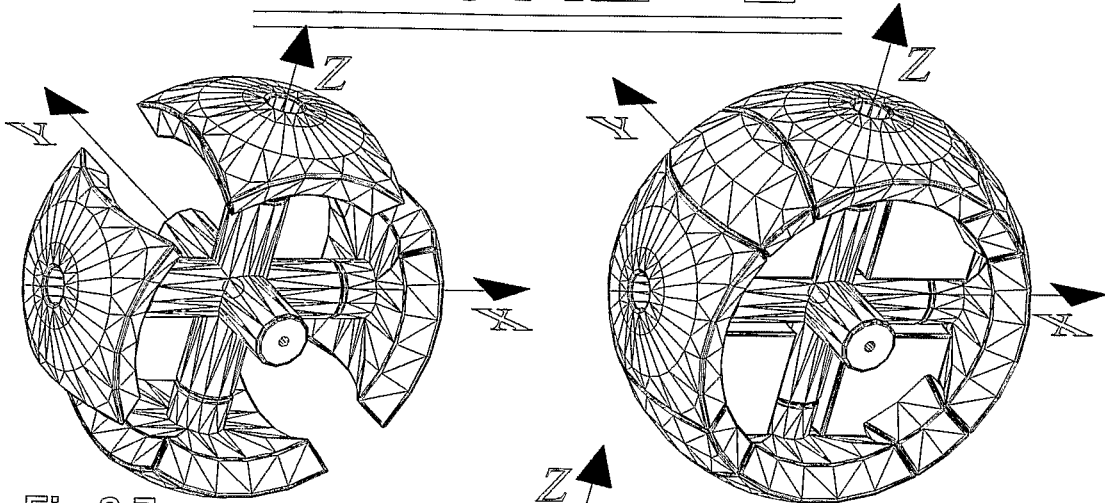

Fig.2.7

Fig.2.8

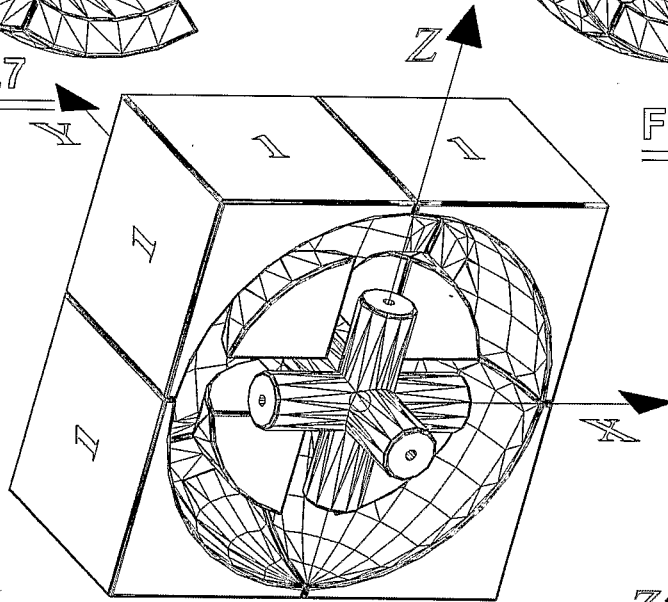

Fig.2.9

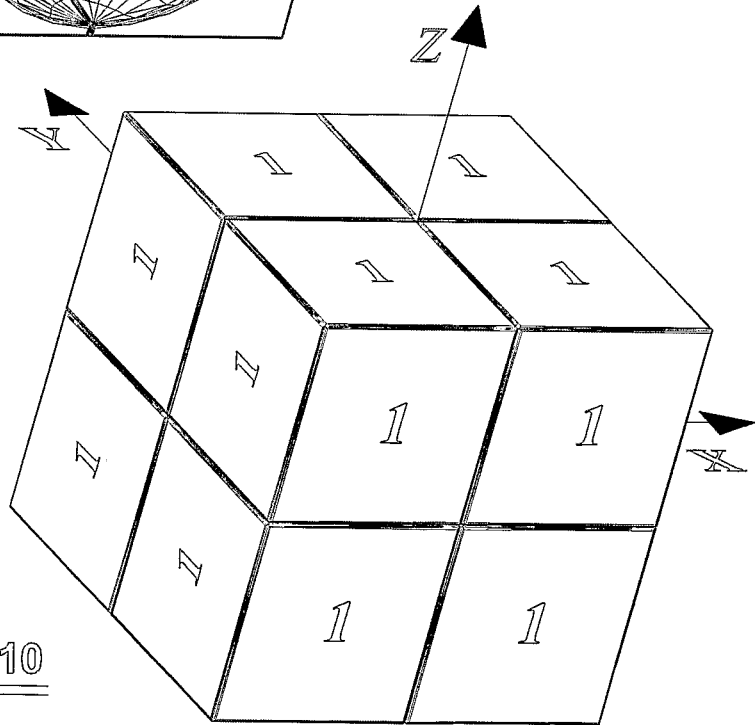

Fig.2.10

FIGURE 3

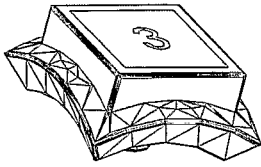

Fig.3.3

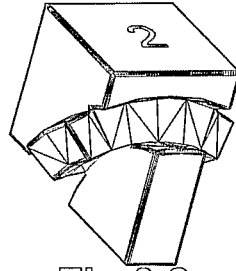

Fig.3.2

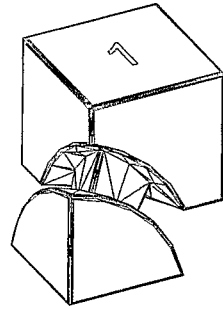

Fig.3.1

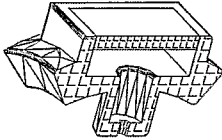

Fig.3.3.1

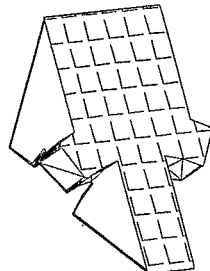

Fig.3.2.2

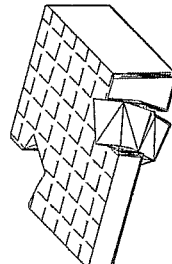

Fig.3.2.1

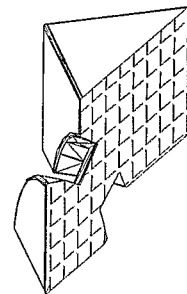

Fig.3.1.1

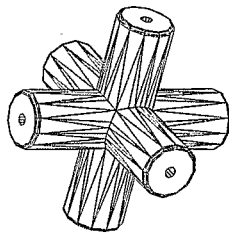

Fig.3.4

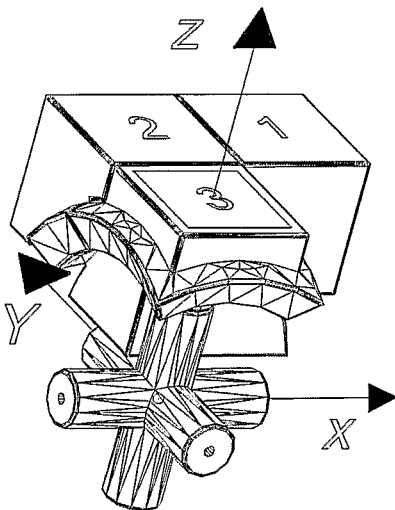

Fig.3.5

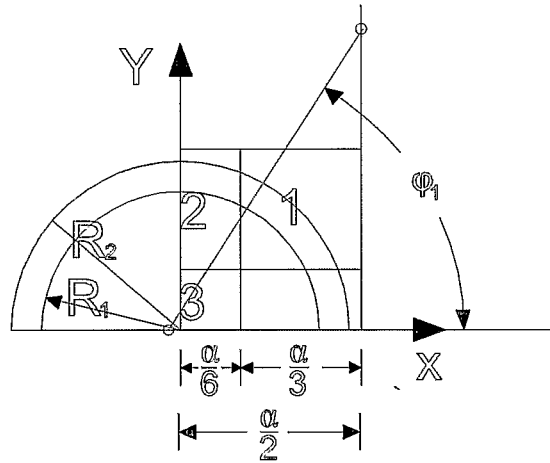

Fig.3.6

FIGURE 3

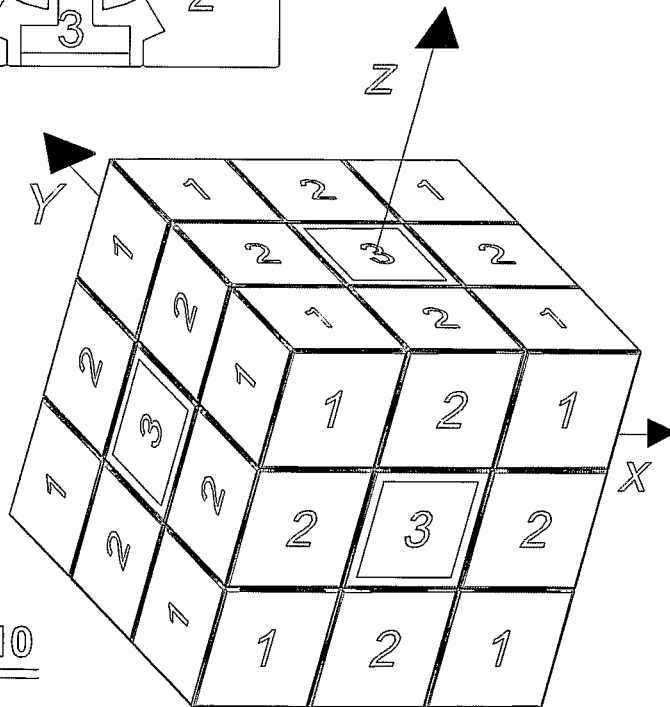
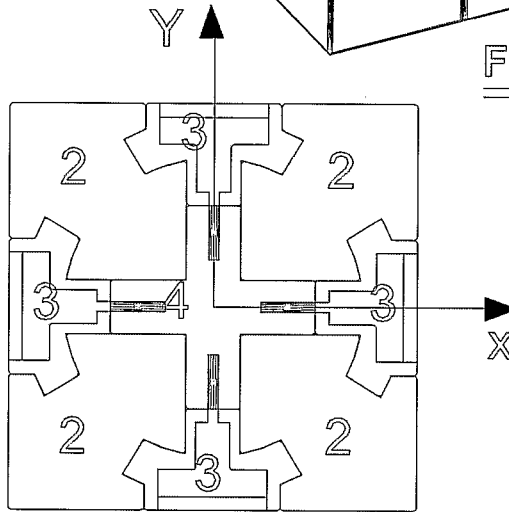
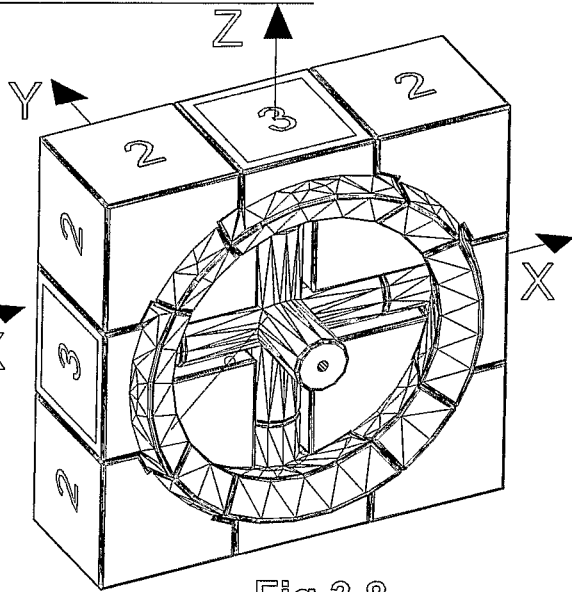
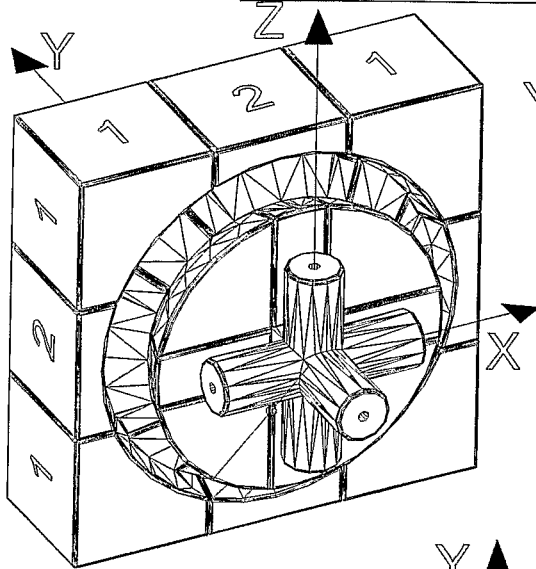

FIGURE 4

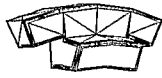

Fig. 4.5

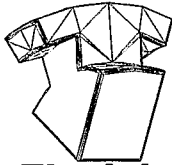

Fig. 4.4



Fig. 4.3

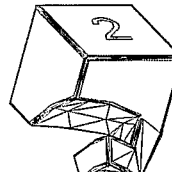

Fig. 4.2

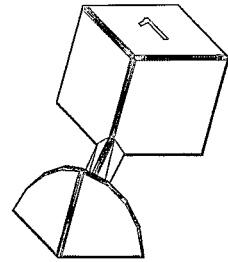

Fig. 4.1

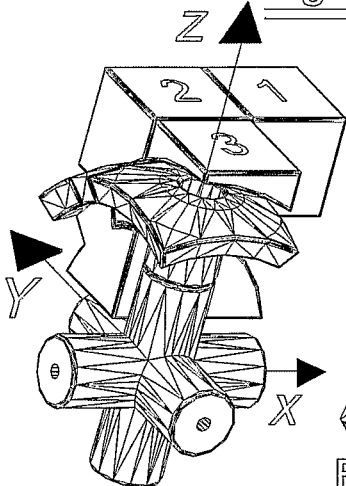

Fig. 4.8

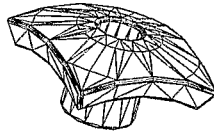

Fig. 4.6

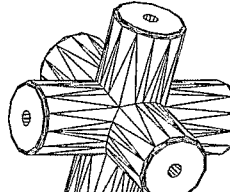

Fig. 4.7

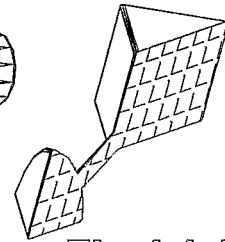

Fig. 4.1.1

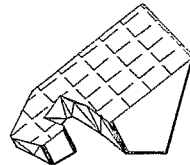

Fig. 4.2.1

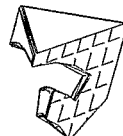

Fig. 4.3.1

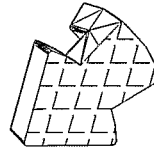

Fig. 4.4.2

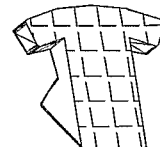

Fig. 4.4.1



Fig. 4.5.1

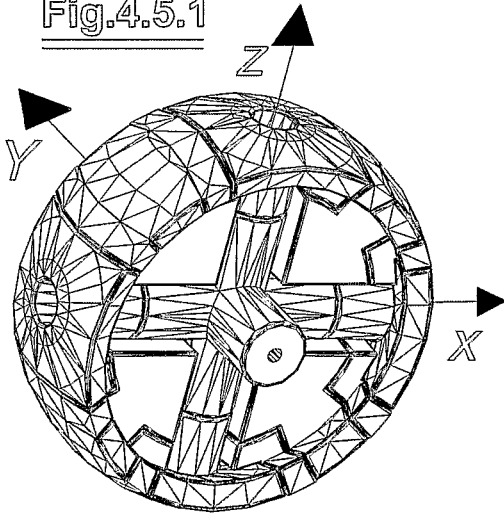

Fig. 4.9

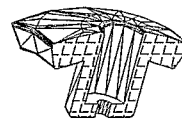

Fig. 4.6.1

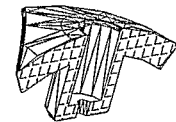

Fig. 4.6.2

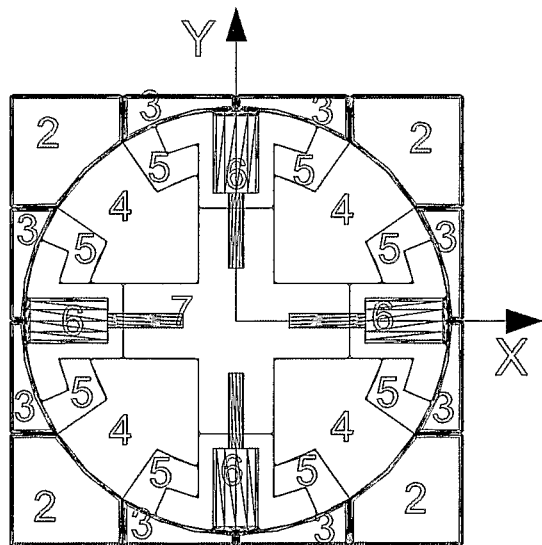

Fig. 4.10

FIGURE 4

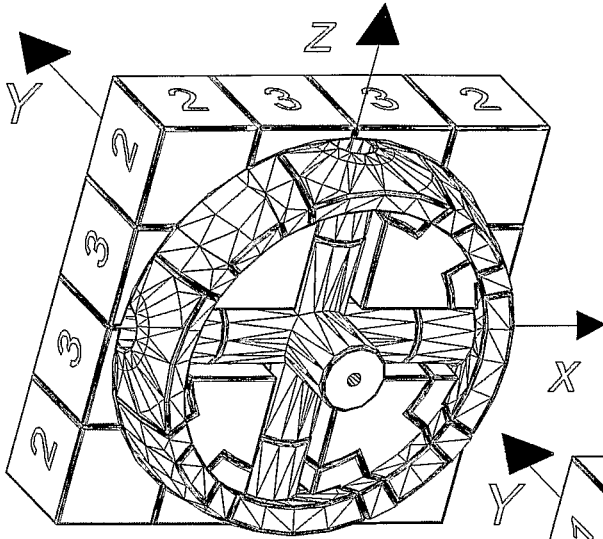

Fig.4.11

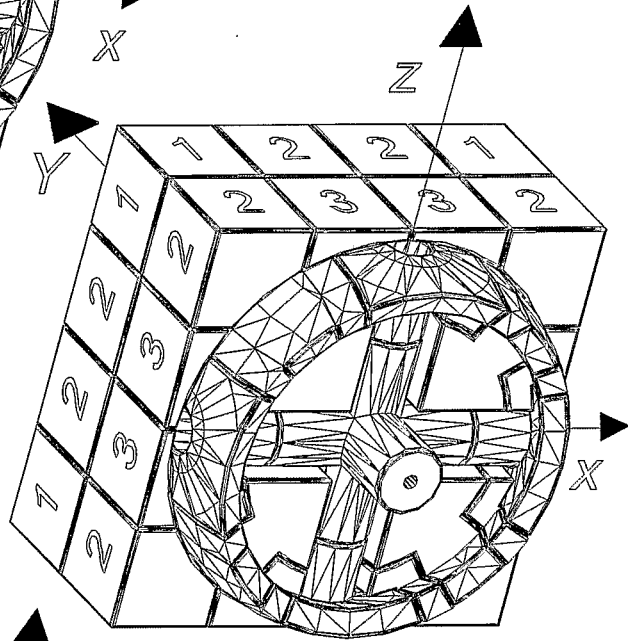

Fig.4.12

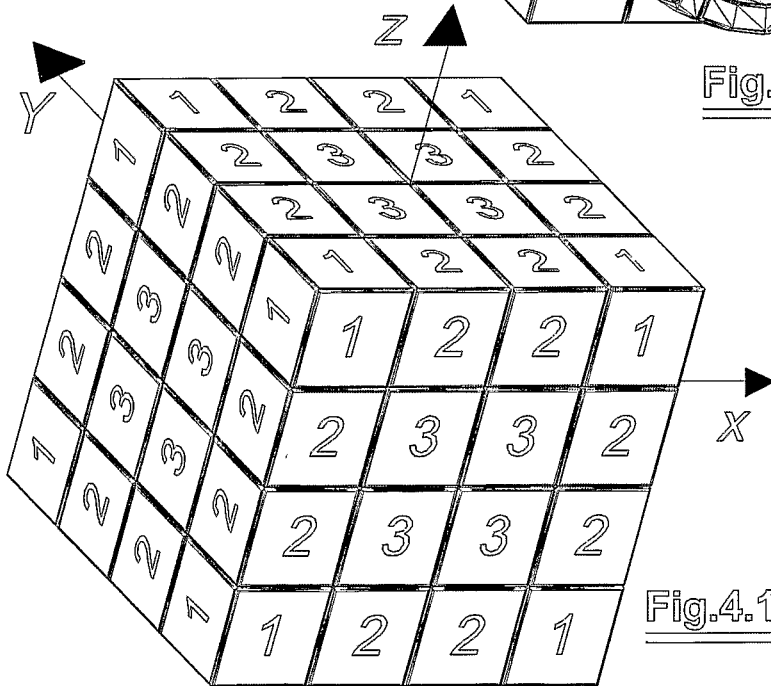

Fig.4.13

FIGURE 4

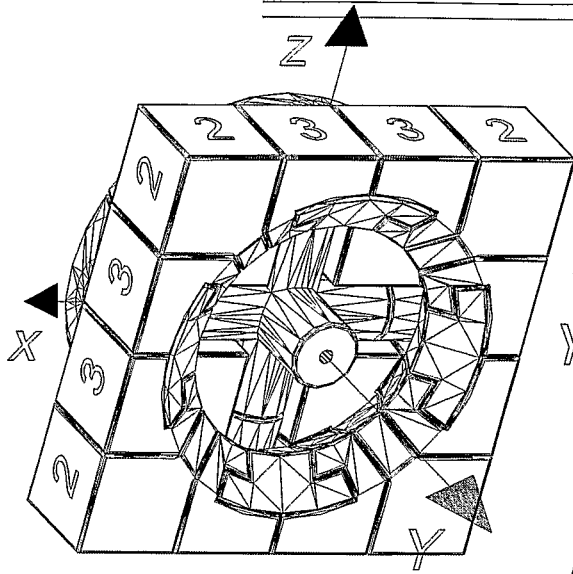

Fig.4.14

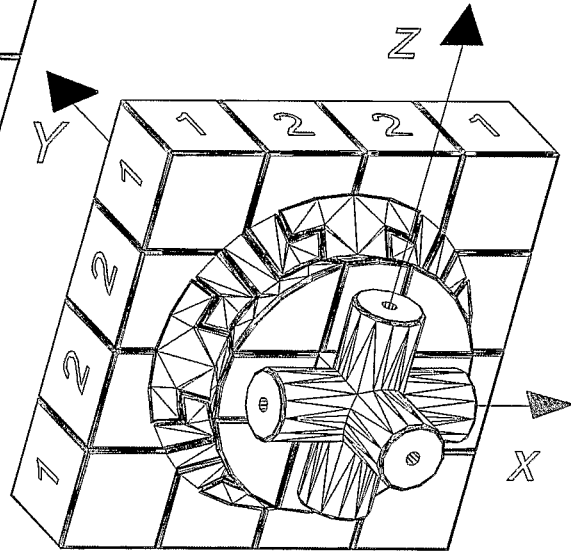

Fig.4.15

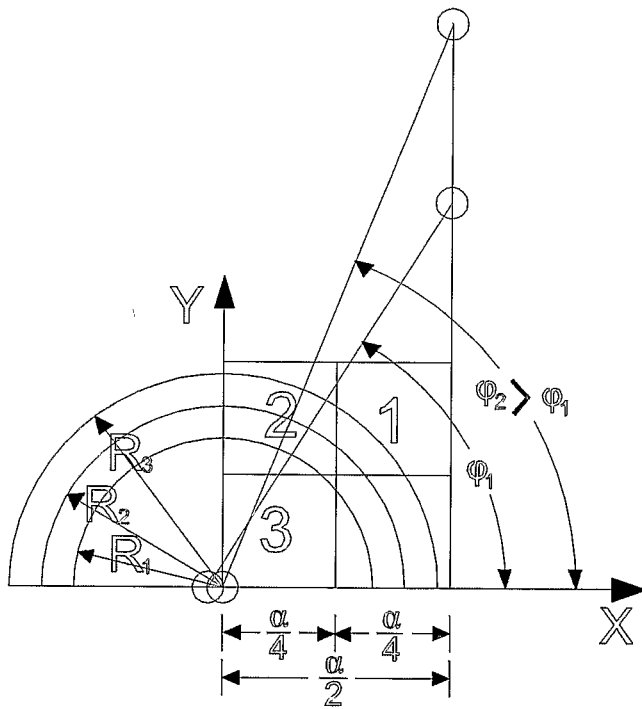

Fig.4.16

FIGURE 5

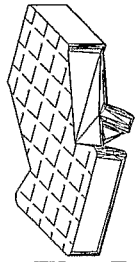

Fig.5.4.1

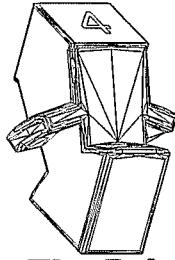

Fig.5.4

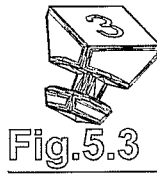

Fig.5.3

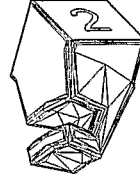

Fig.5.2

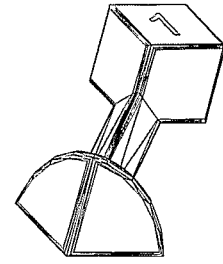

Fig.5.1

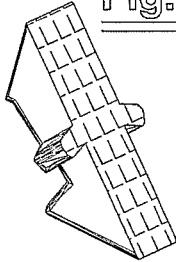

Fig.5.4.2

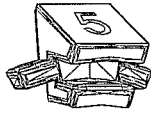

Fig.5.5

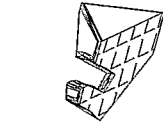

Fig.5.3.1

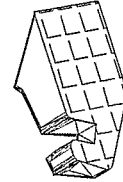

Fig.5.2.1

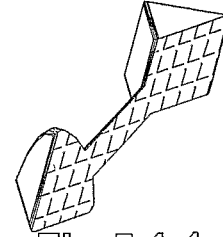

Fig.5.1.1

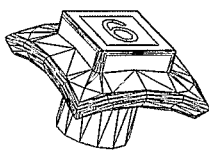

Fig.5.6

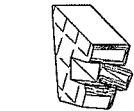

Fig.5.5.1

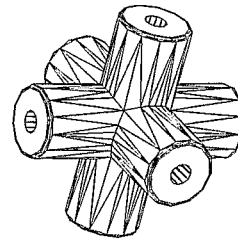

Fig.5.7

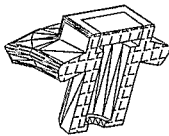

Fig.5.6.1

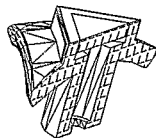

Fig.5.6.2

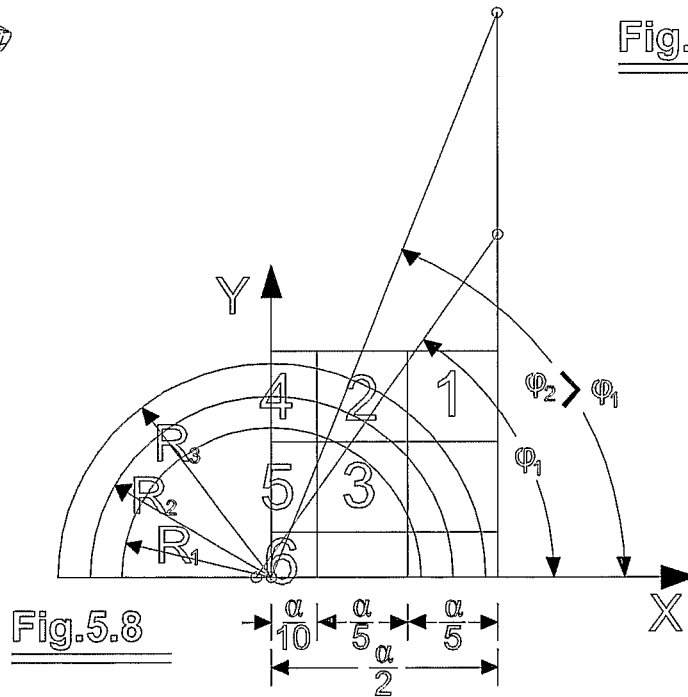

FIGURE 5

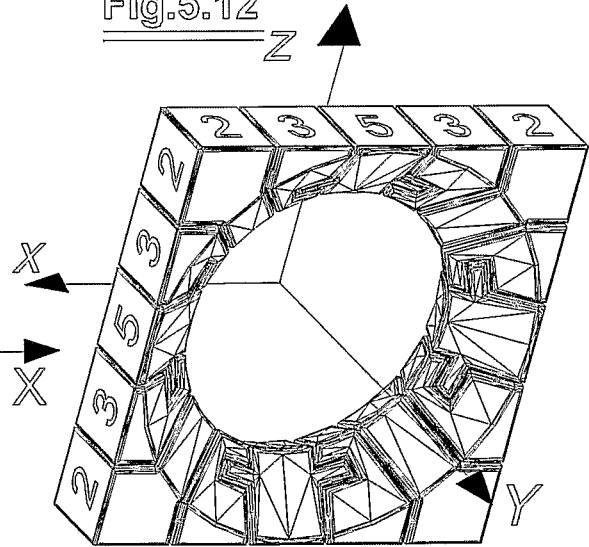
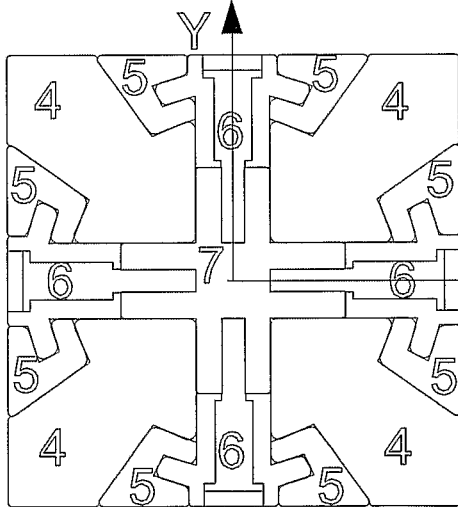
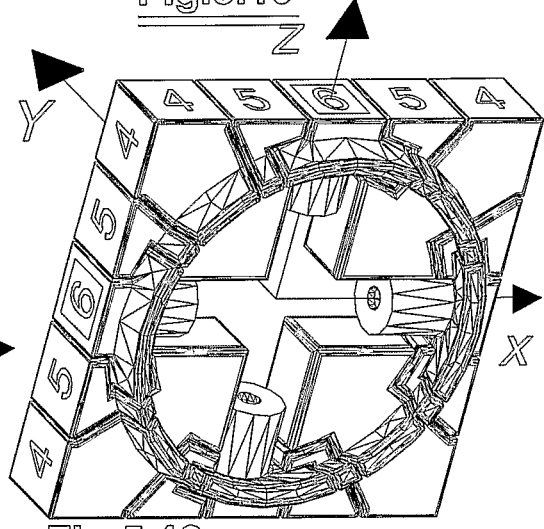
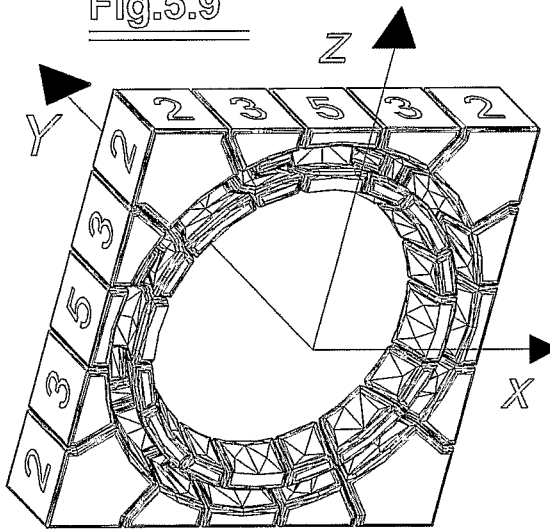
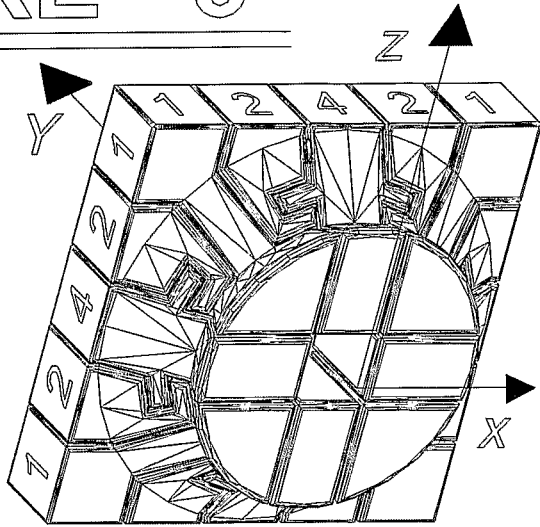
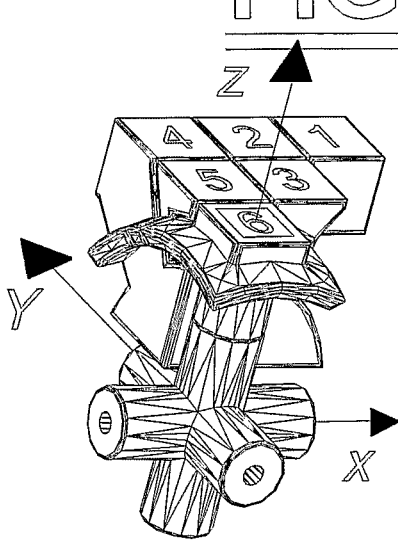

FIGURE 5

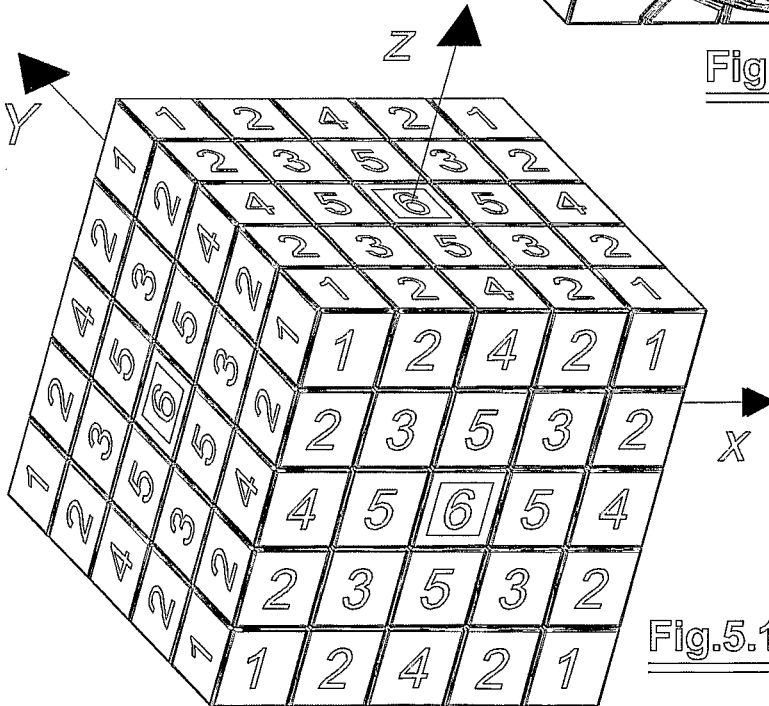
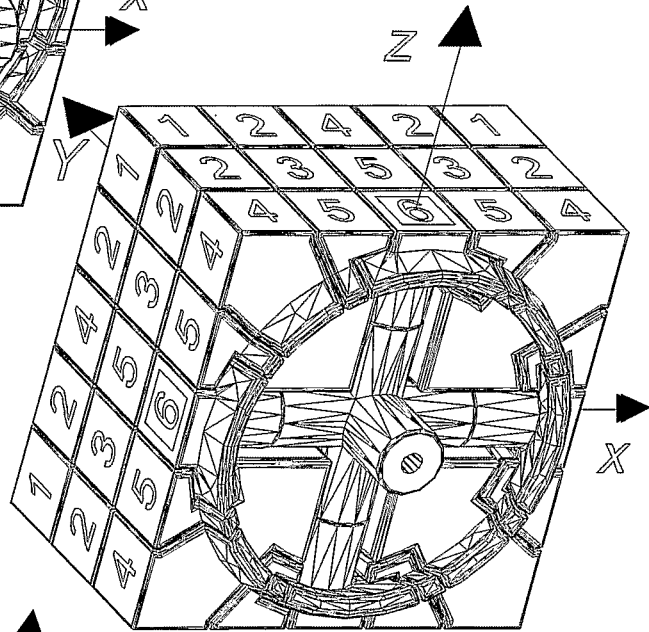
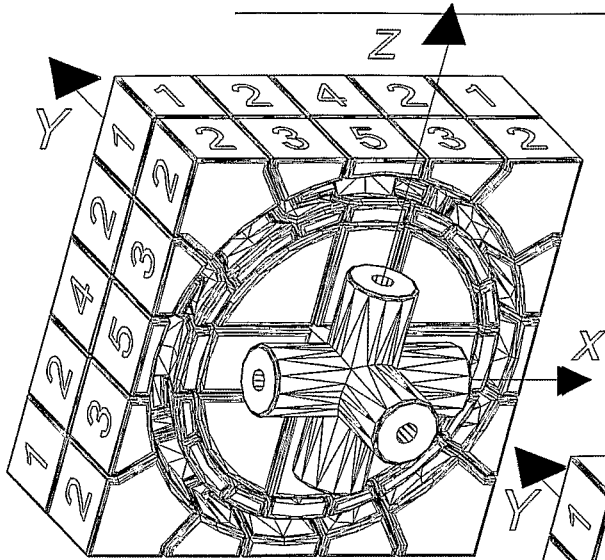

FIGURE 6a



Fig. 6a.5

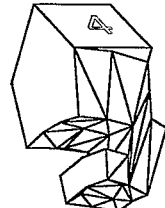

Fig. 6a.4

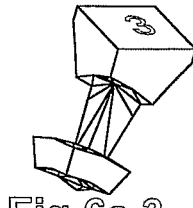

Fig. 6a.3

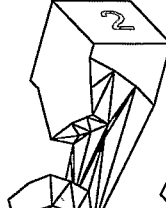

Fig. 6a.2

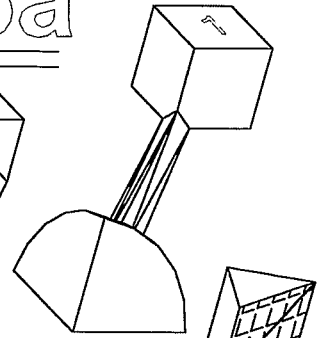

Fig. 6a.1

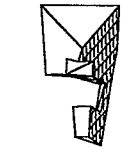

Fig. 6a.5.1

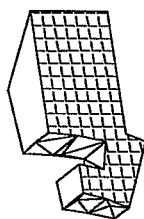

Fig. 6a.4.1

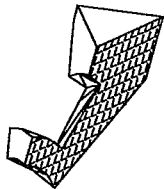

Fig. 6a.3.1

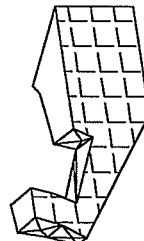

Fig. 6a.2.1

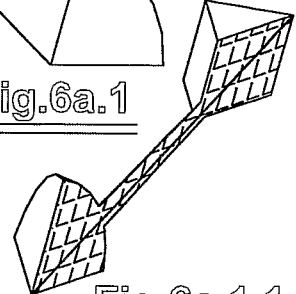

Fig. 6a.1.1

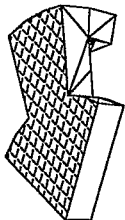

Fig. 6a.7.2

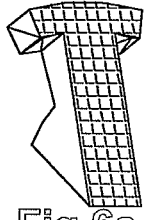

Fig. 6a.7.1

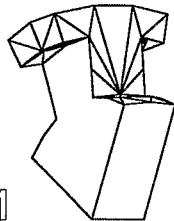

Fig. 6a.7

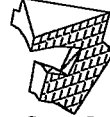

Fig. 6a.6.1

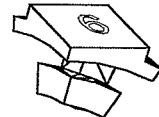

Fig. 6a.6



Fig. 6a.9.1



Fig. 6a.9



Fig. 6a.8.1

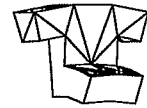

Fig. 6a.8

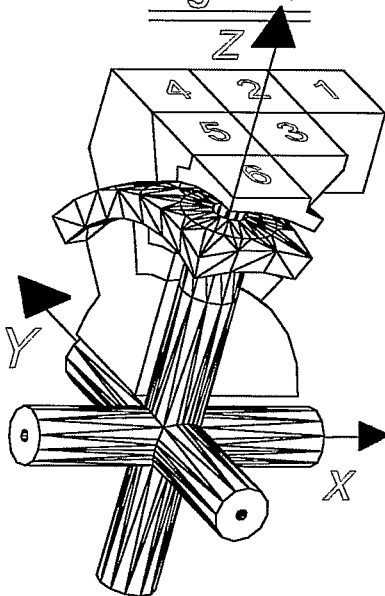

Fig. 6a.12



Fig. 6a.10



Fig. 6a.10.1

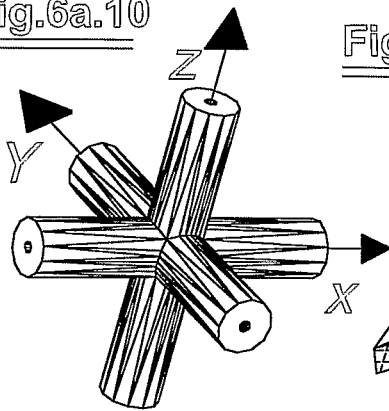

Fig. 6a.11

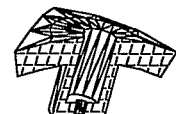

Fig. 6a.10.2

FIGURE 6a

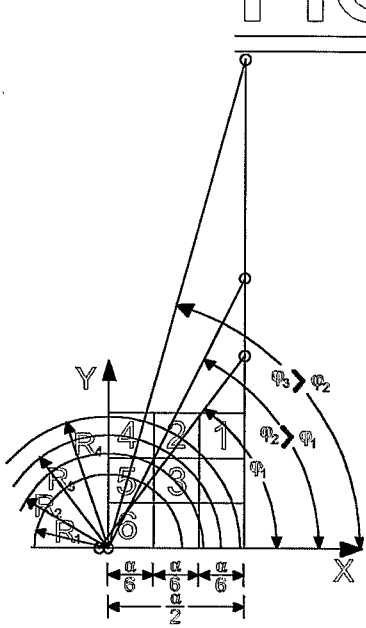

Fig.6a.13

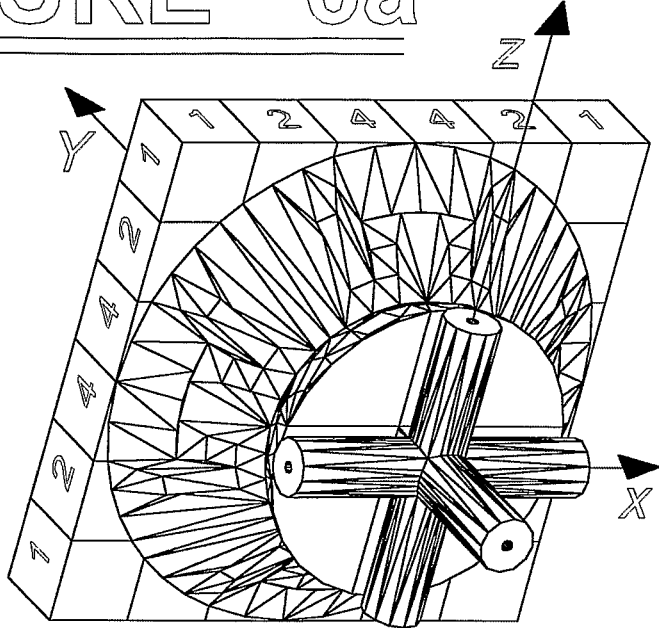

Fig.6a.14

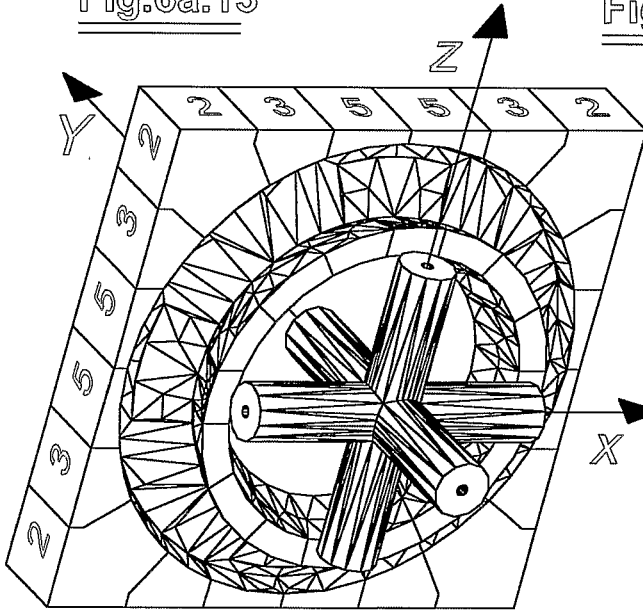

Fig.6a.15

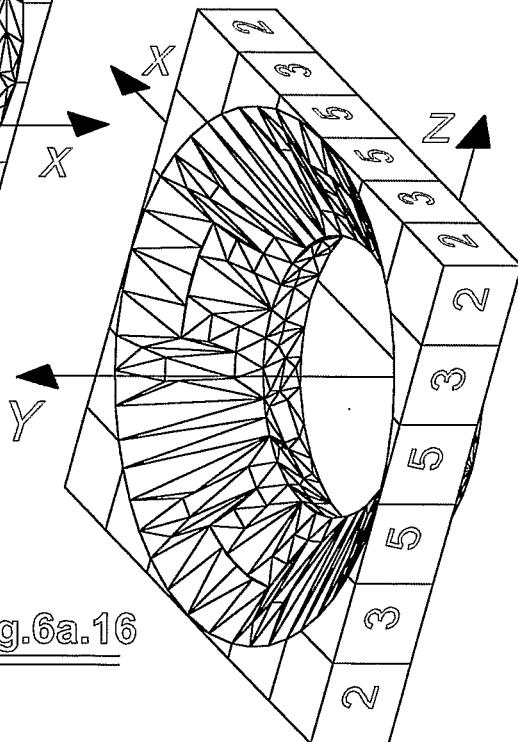

Fig.6a.16

FIGURE 6a

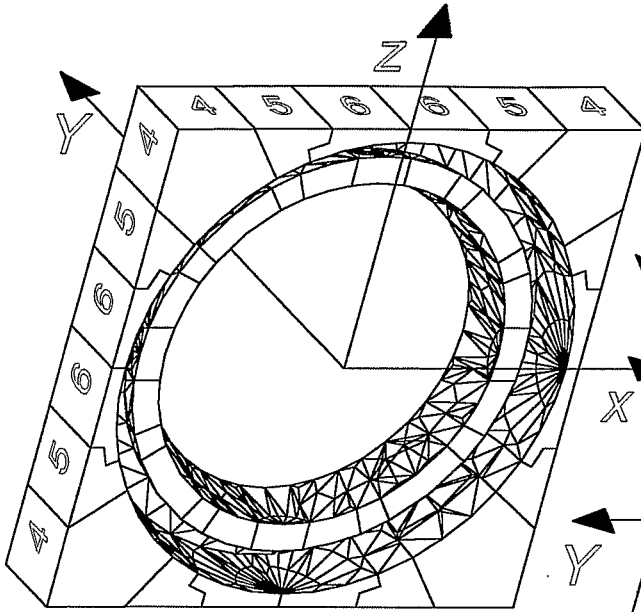

Fig.6a.17

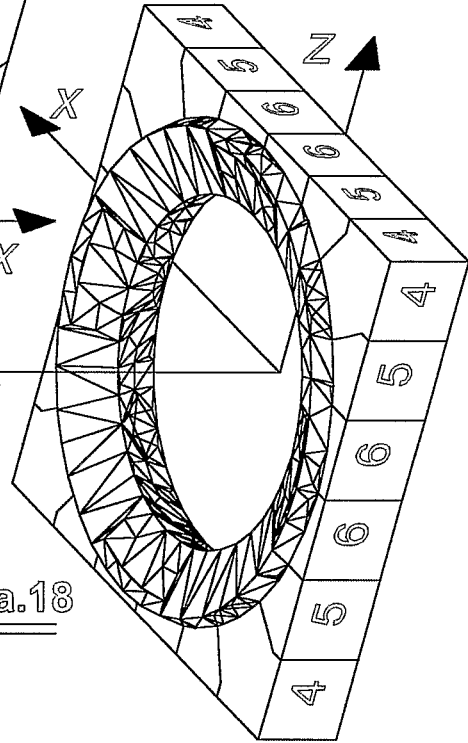

Fig.6a.18

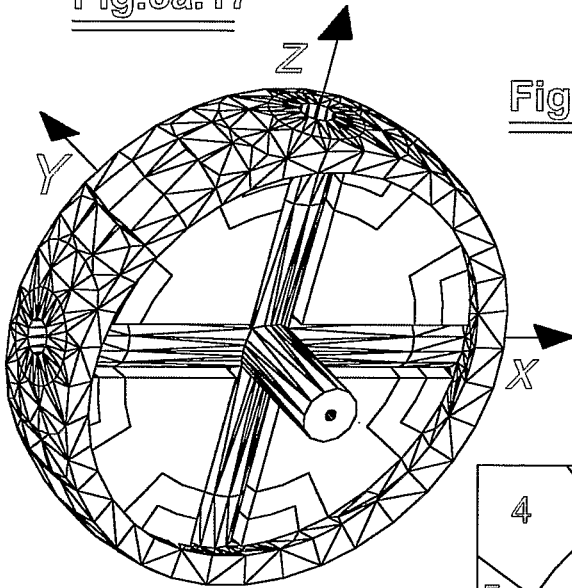

Fig.6a.19

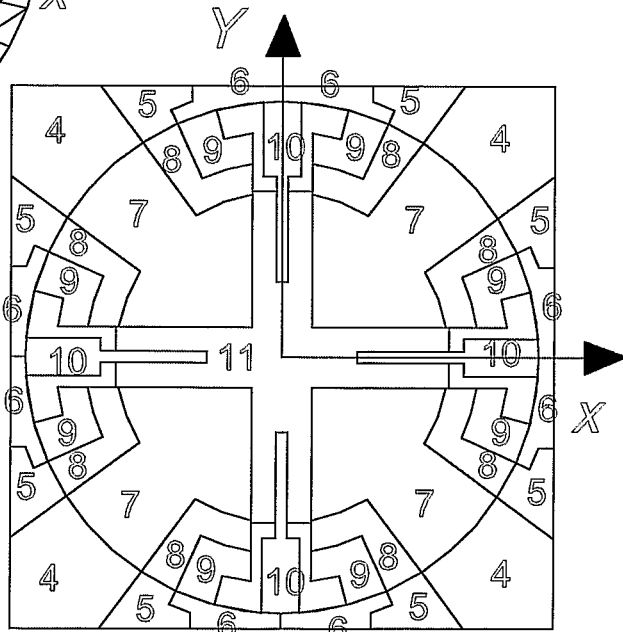

Fig.6a.20

FIGURE 6a

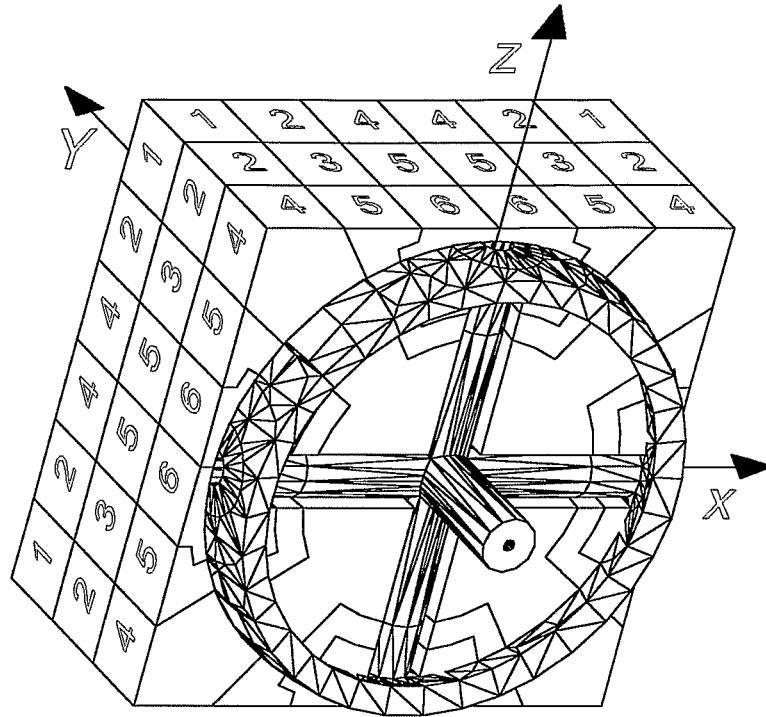

Fig.6a.21

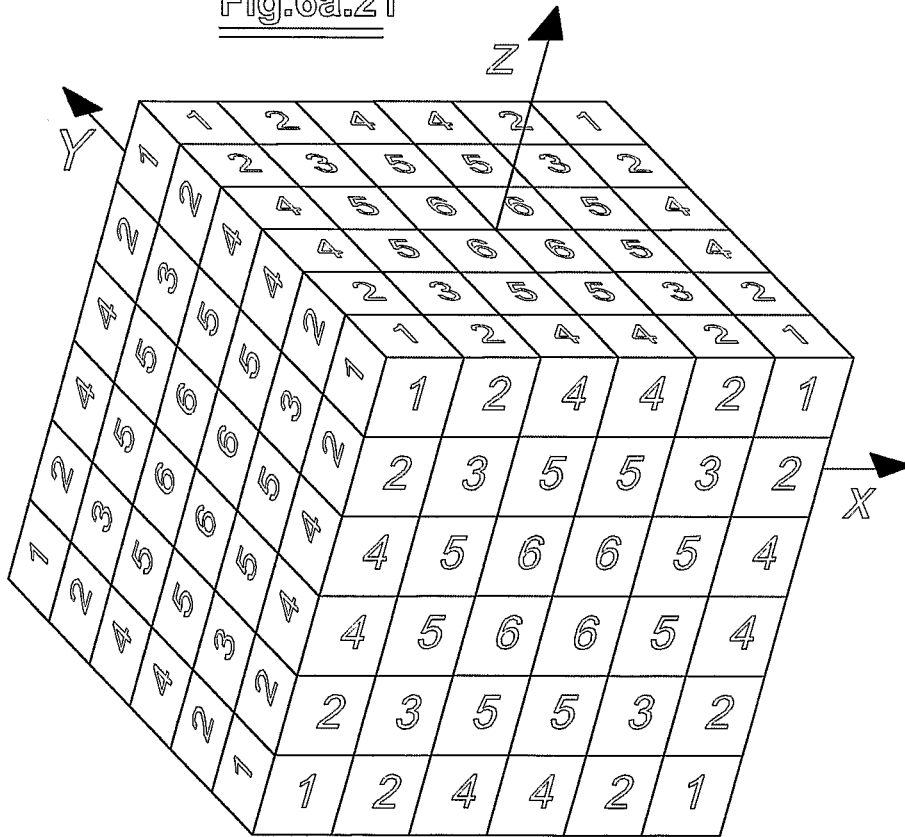

Fig.6a.22

FIGURE 6b



Fig. 6b.5

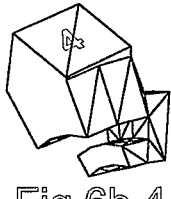

Fig. 6b.4

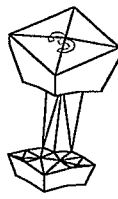

Fig. 6b.3



Fig. 6b.2

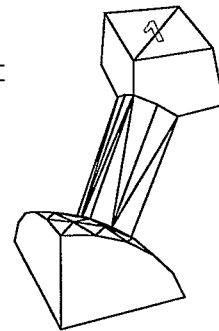

Fig. 6b.1

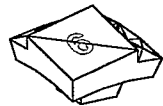

Fig. 6b.6

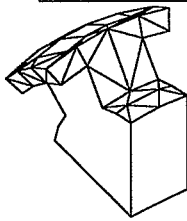

Fig. 6b.7

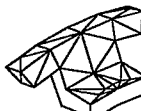

Fig. 6b.8

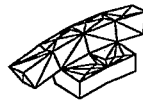

Fig. 6b.9

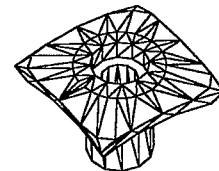

Fig. 6b.10

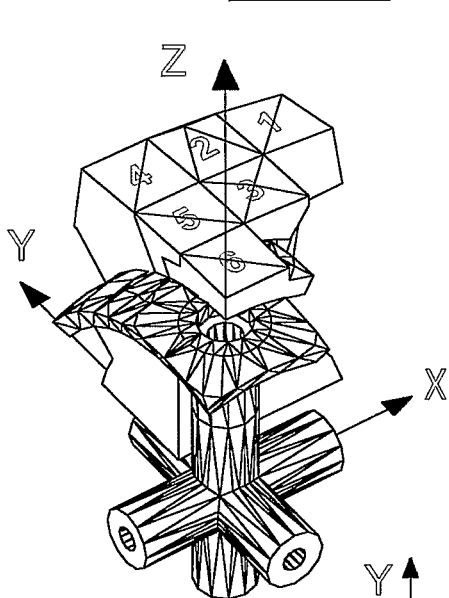

Fig. 6b.12

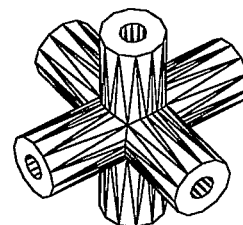

Fig. 6b.11

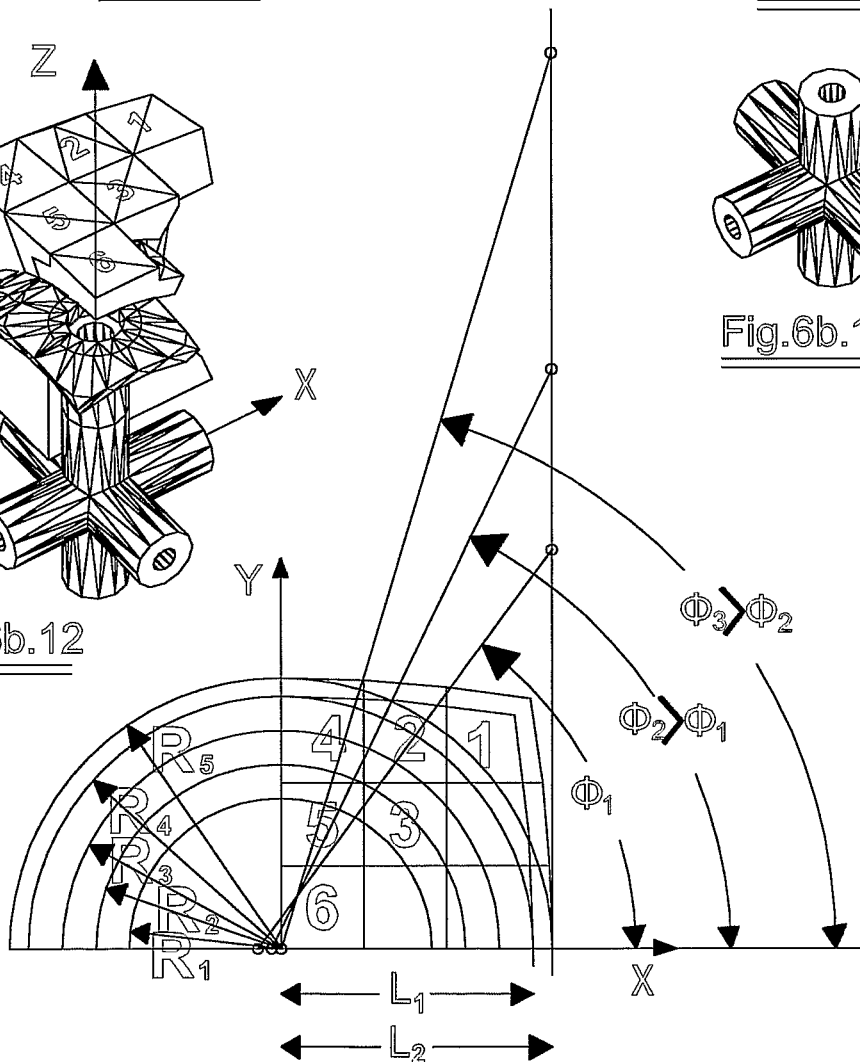

Fig. 6b.13

FIGURE 6b

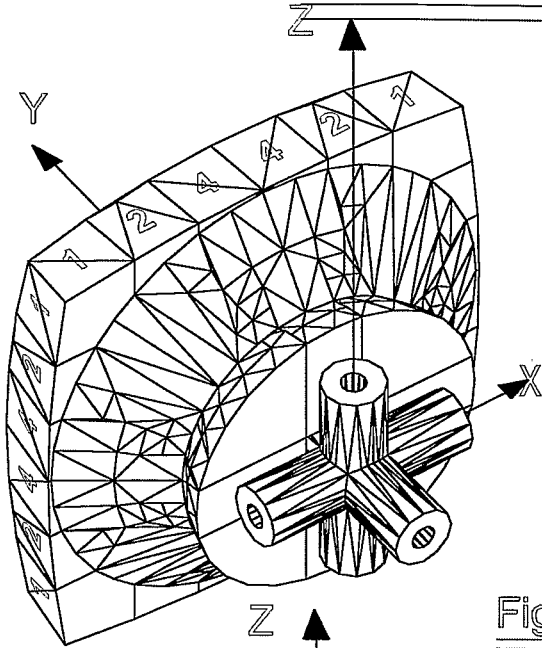

Fig.6b.14

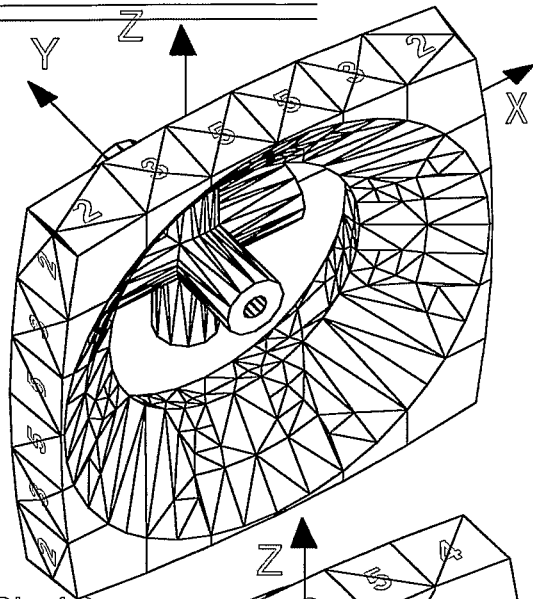

Fig.6b.16

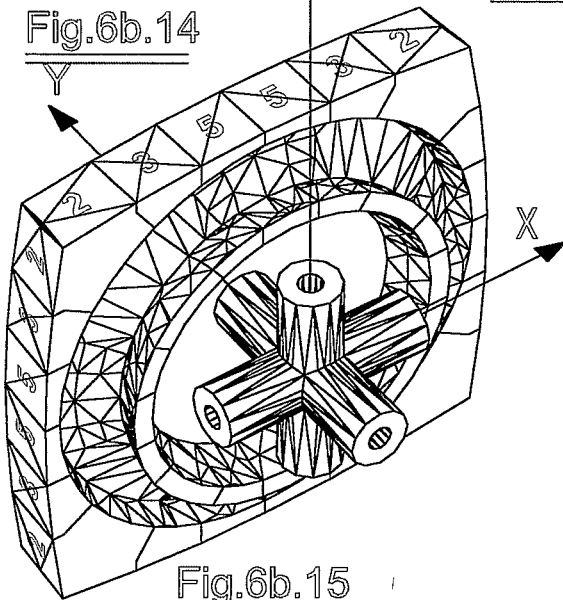

Fig.6b.15

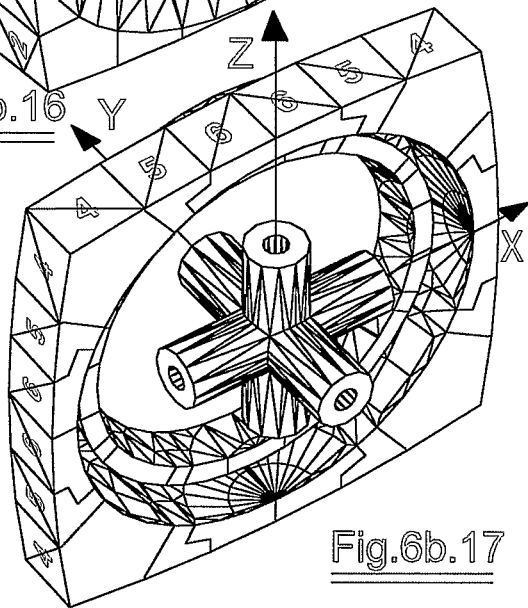

Fig.6b.17

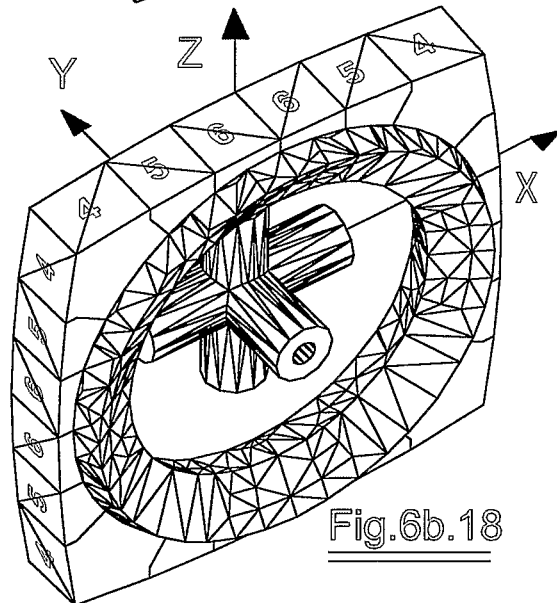

Fig.6b.18

FIGURE 6b

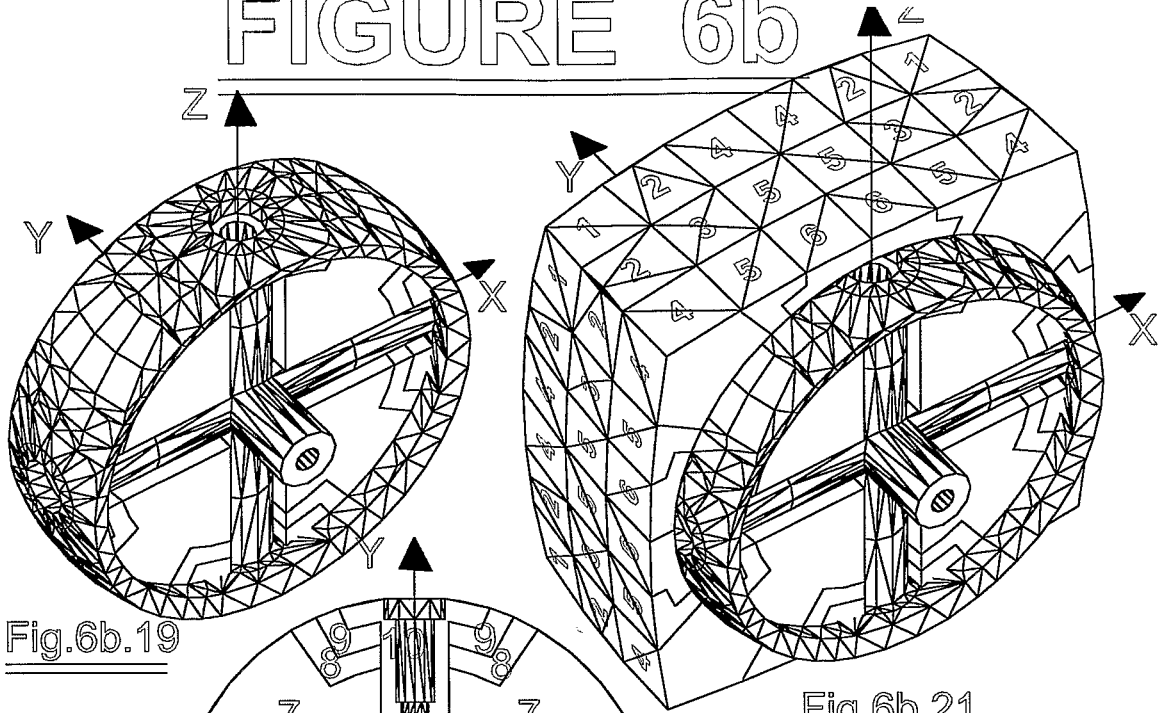

Fig. 6b.19

Fig. 6b.21

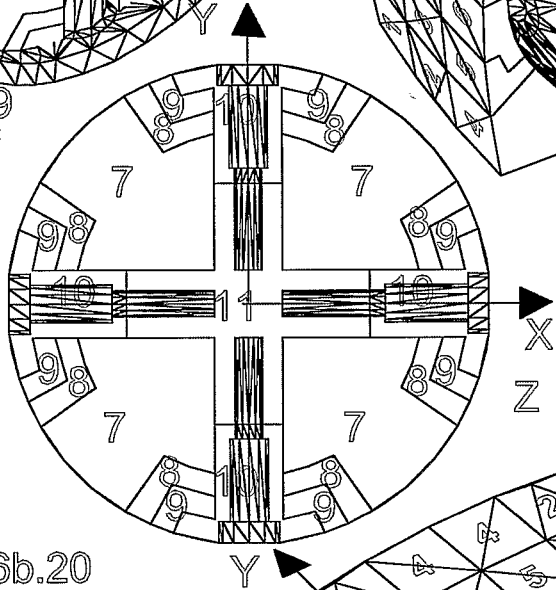

Fig. 6b.20

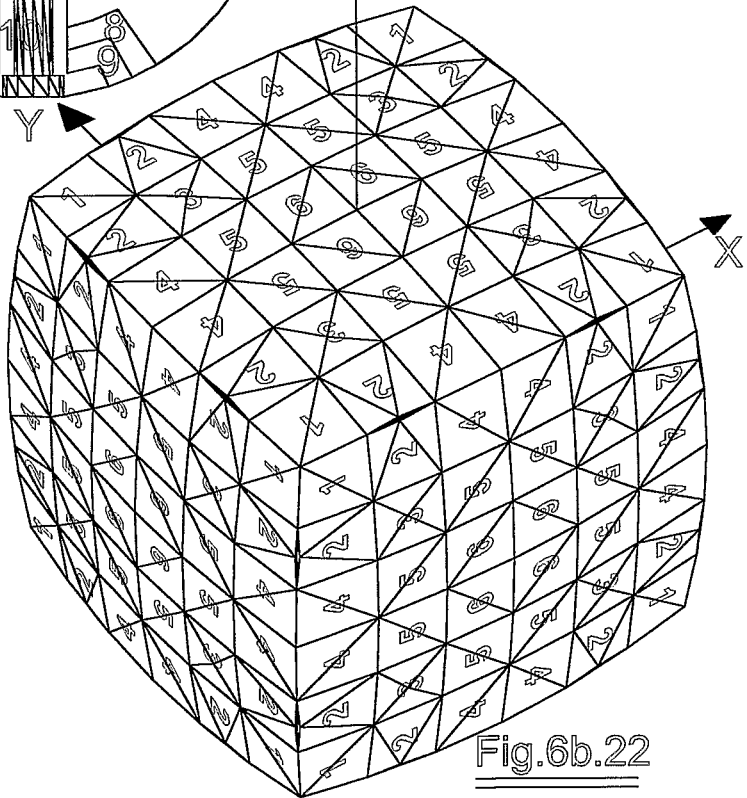

Fig. 6b.22

FIGURE 7

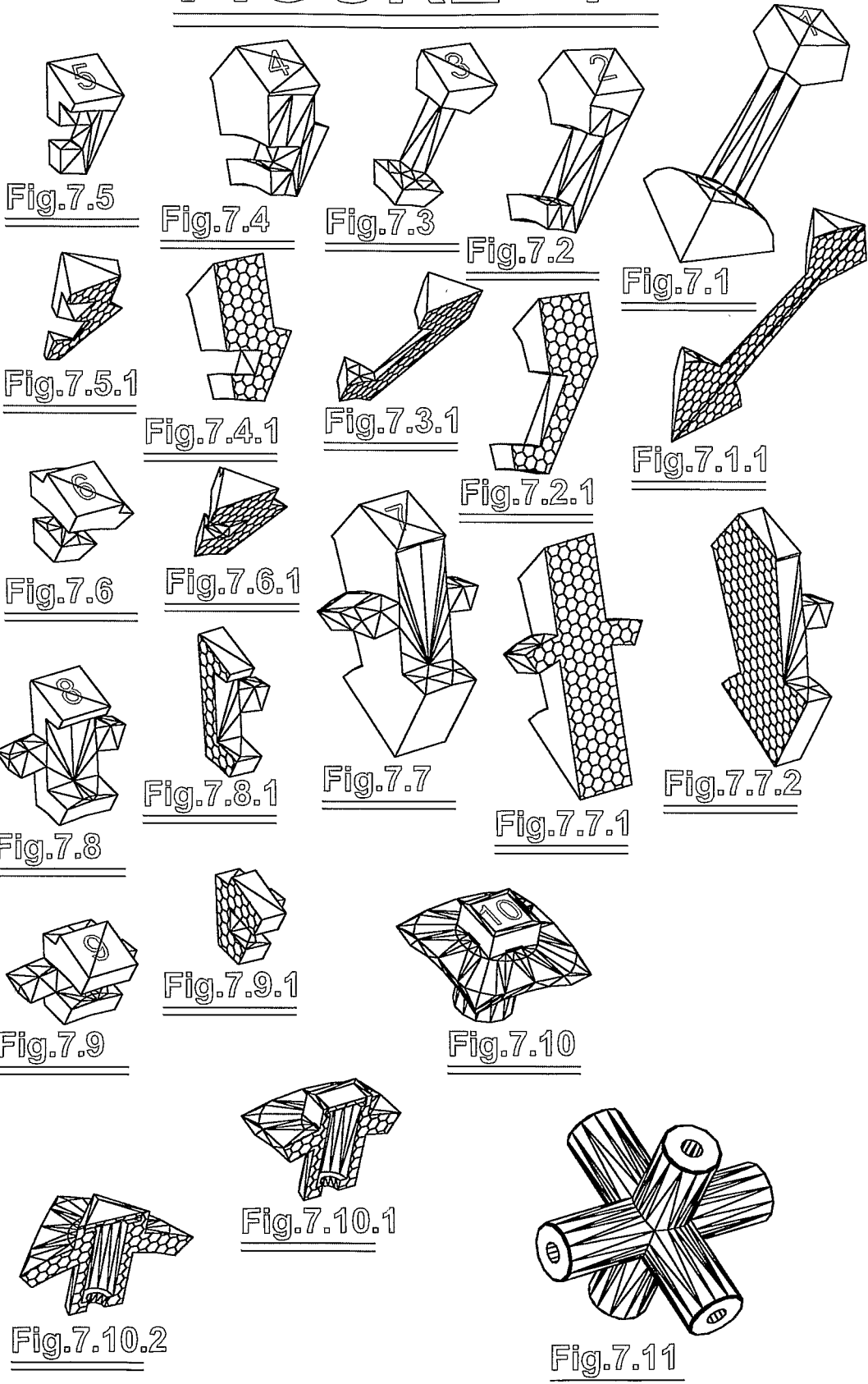

FIGURE 7

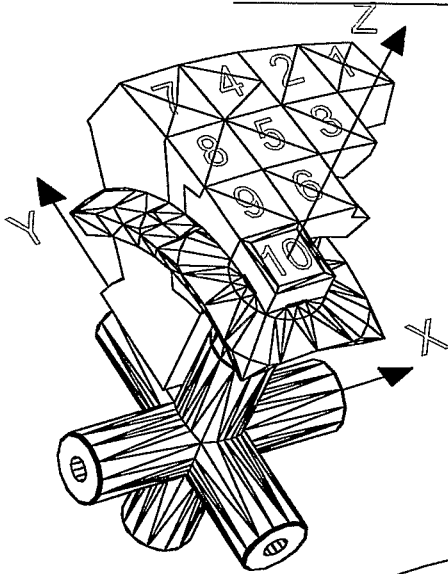

Fig.7.12

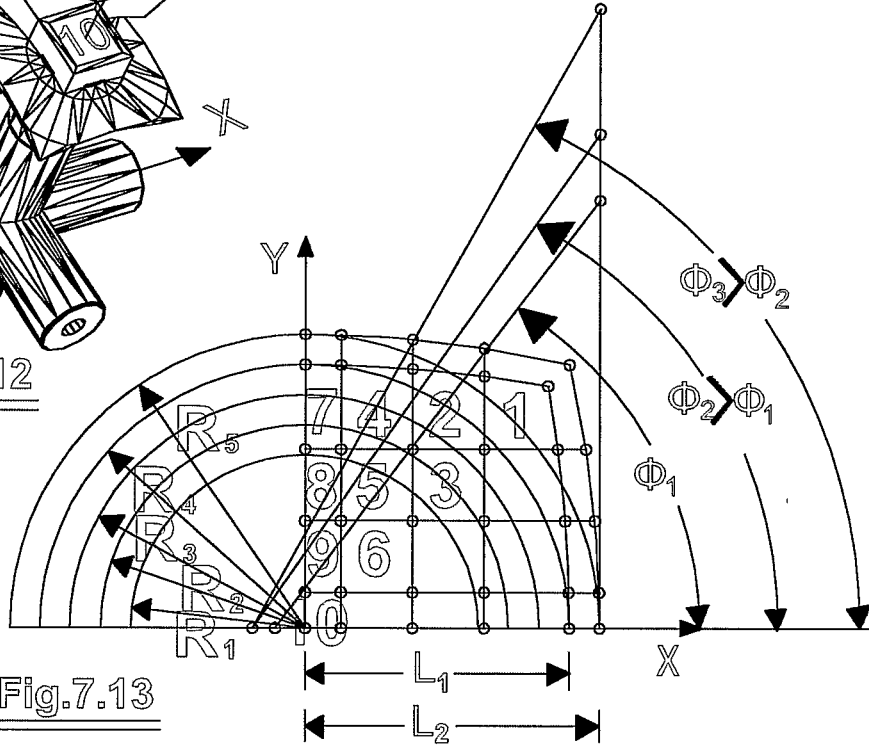

Fig.7.13

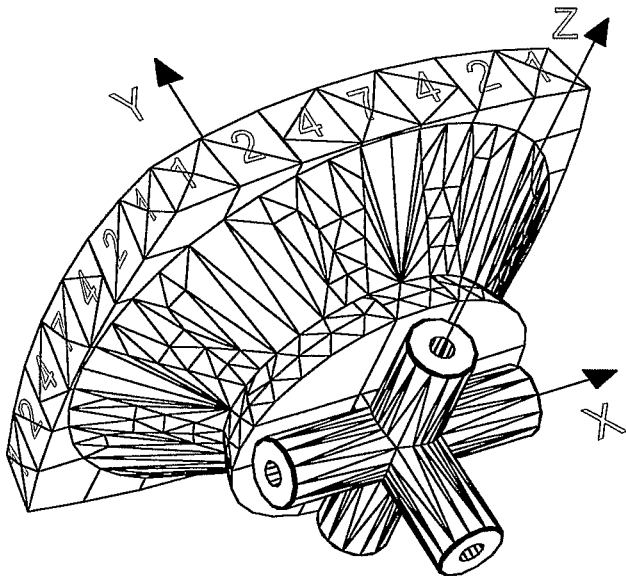

Fig.7.14

FIGURE 7

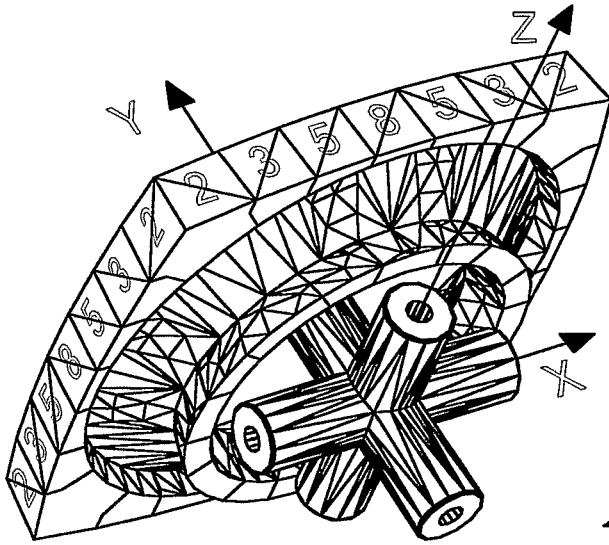

Fig.7.15

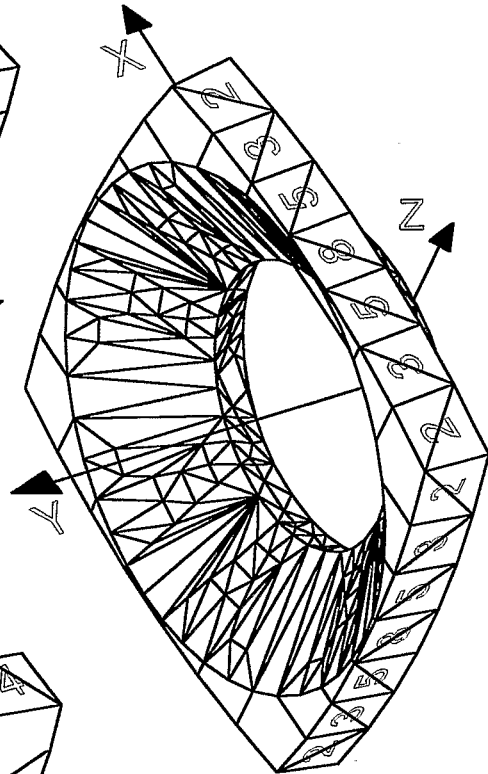

Fig.7.16

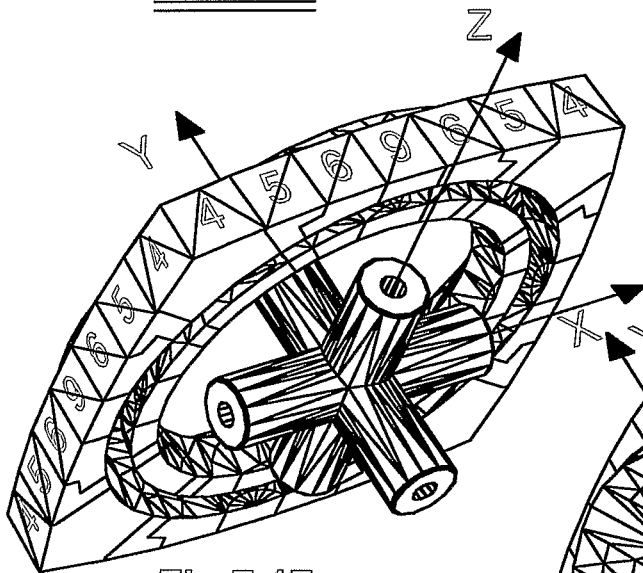

Fig.7.17

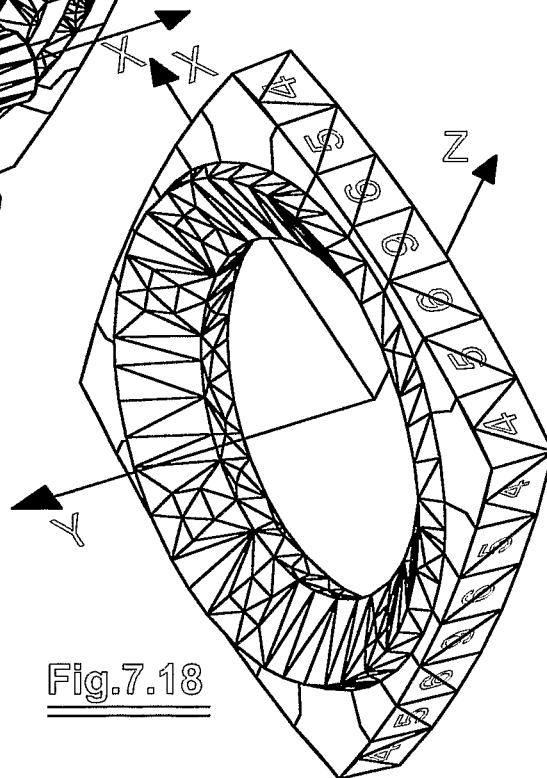

Fig.7.18

FIGURE 7

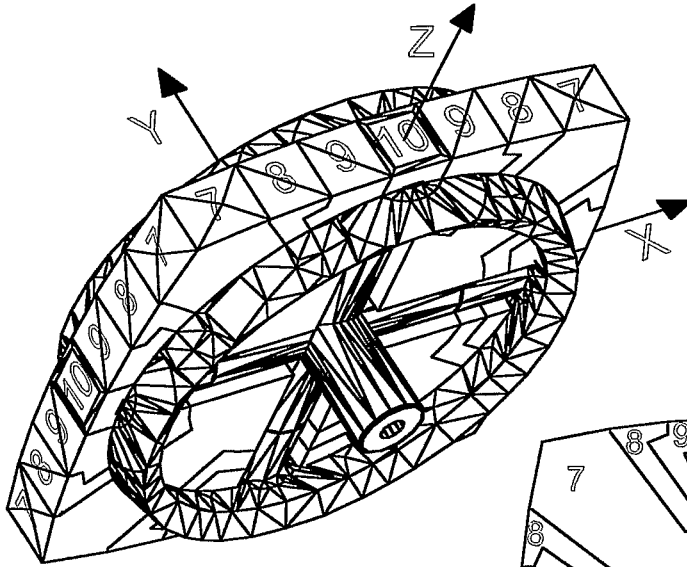

Fig.7.19

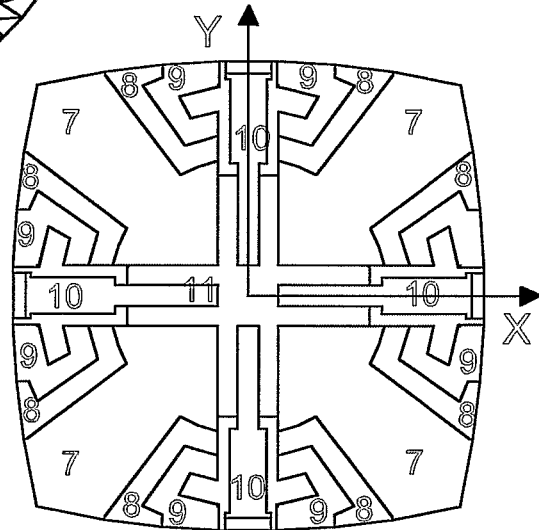

Fig.7.20

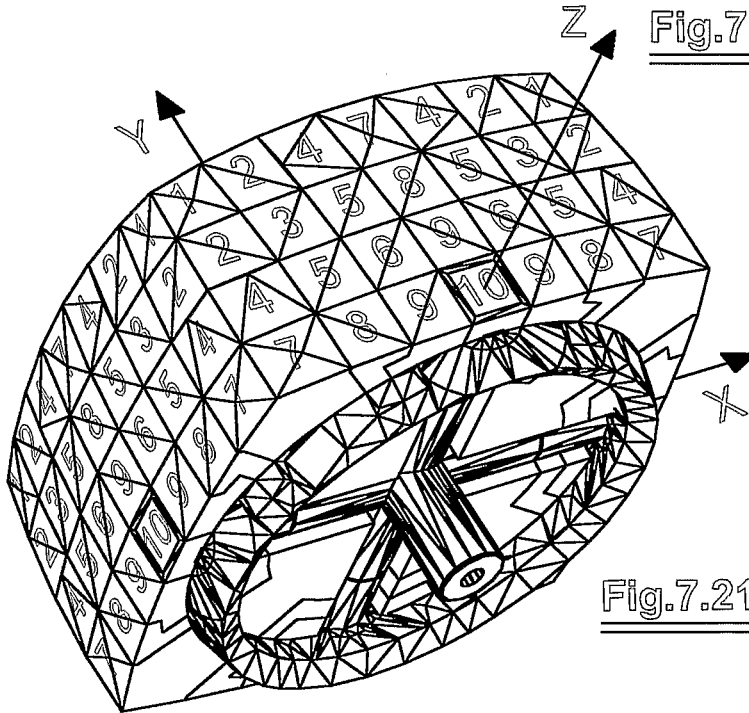

Fig.7.21

FIGURE 7

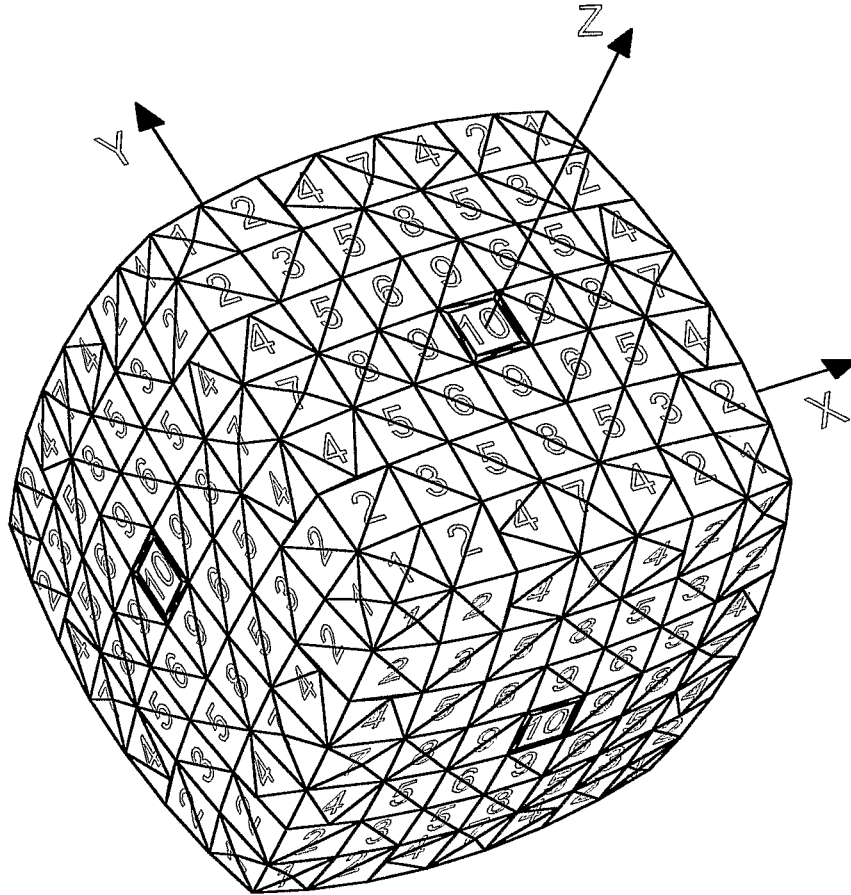

Fig.7.22

FIGURE 8

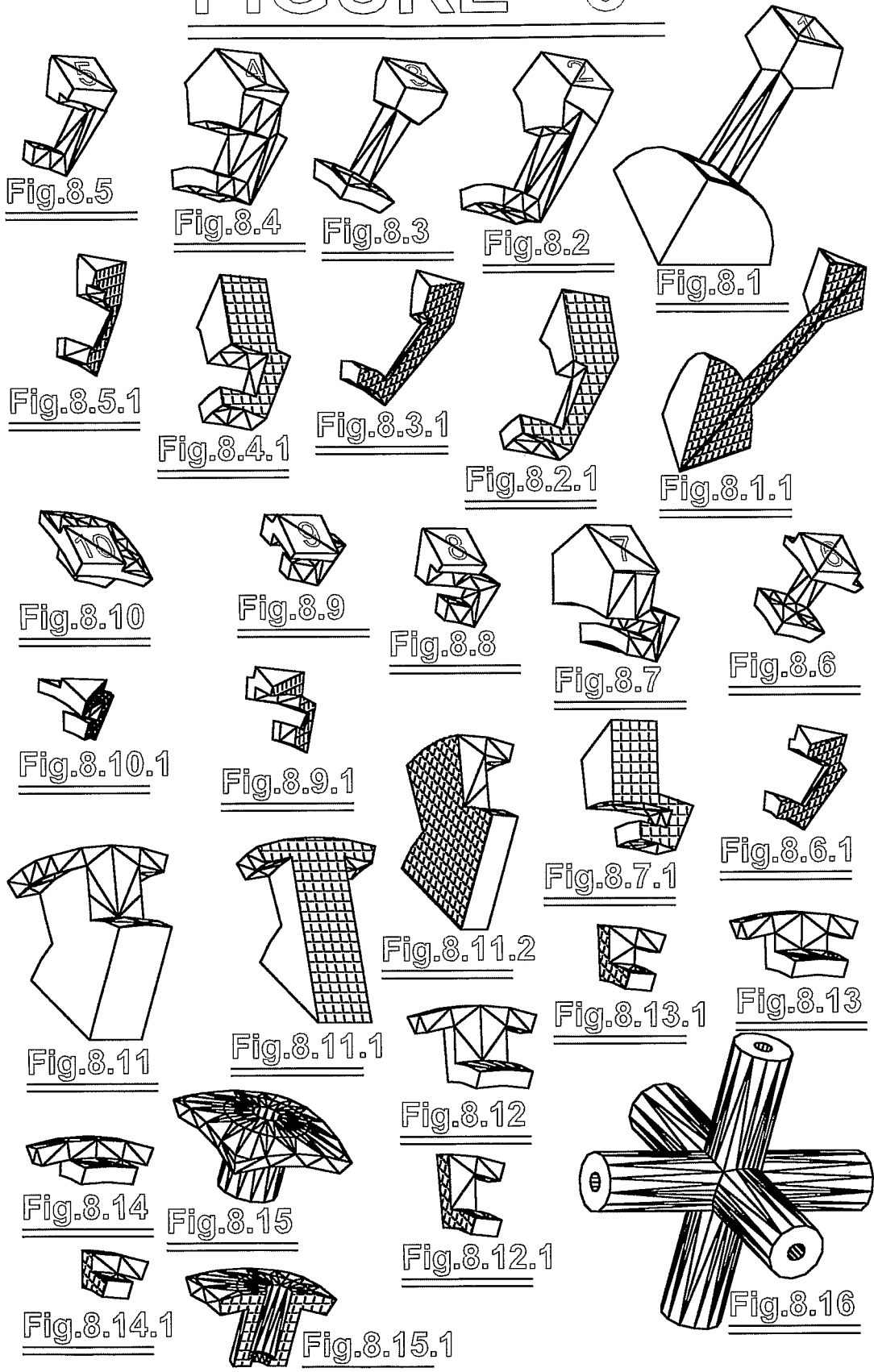

FIGURE 8

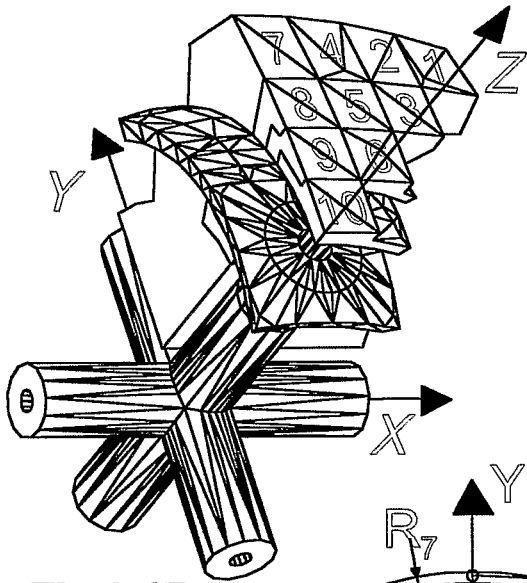

Fig.8.17

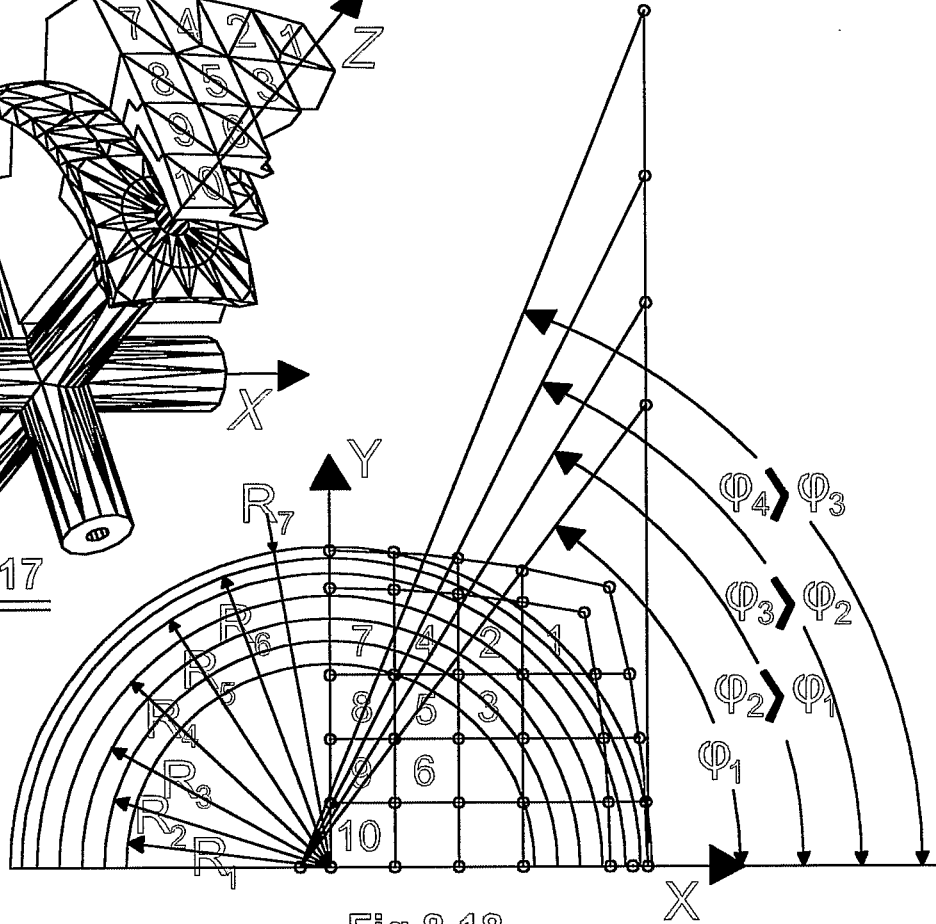

Fig.8.18

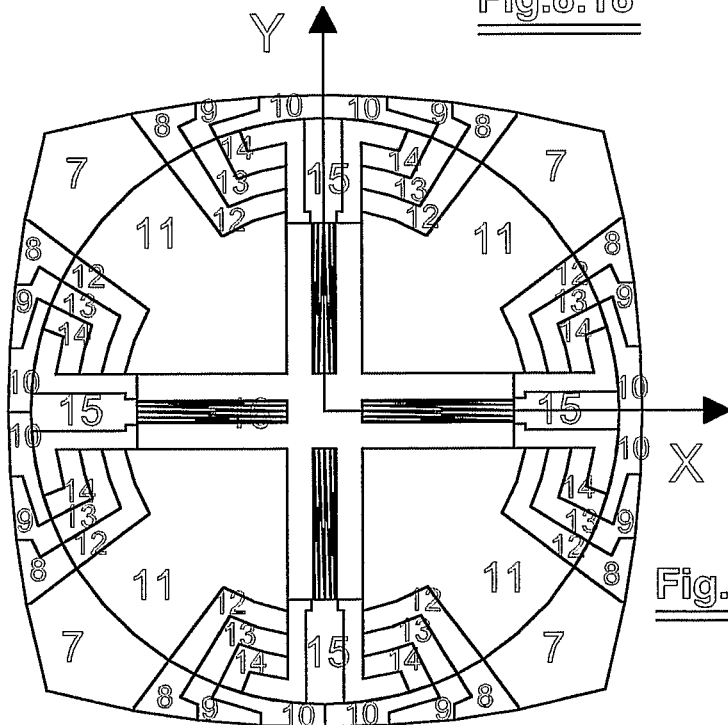

Fig.8.19

FIGURE 8

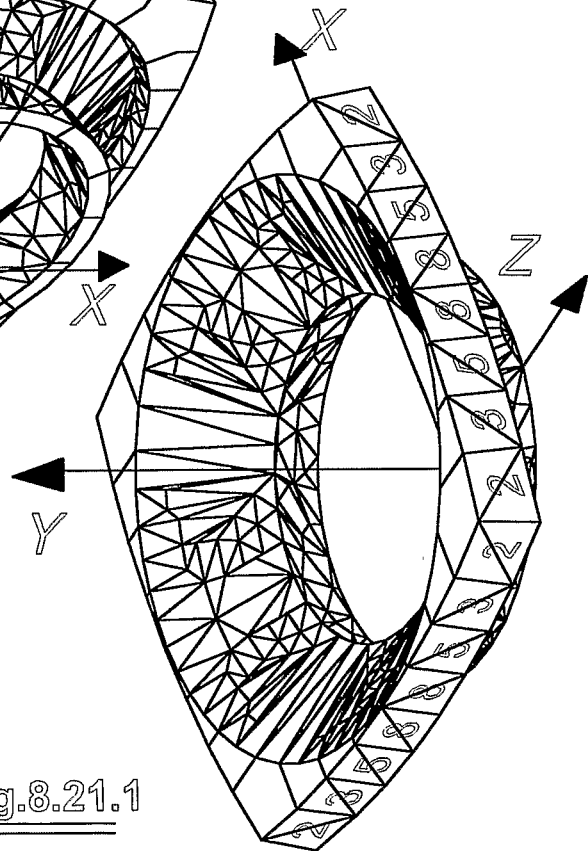
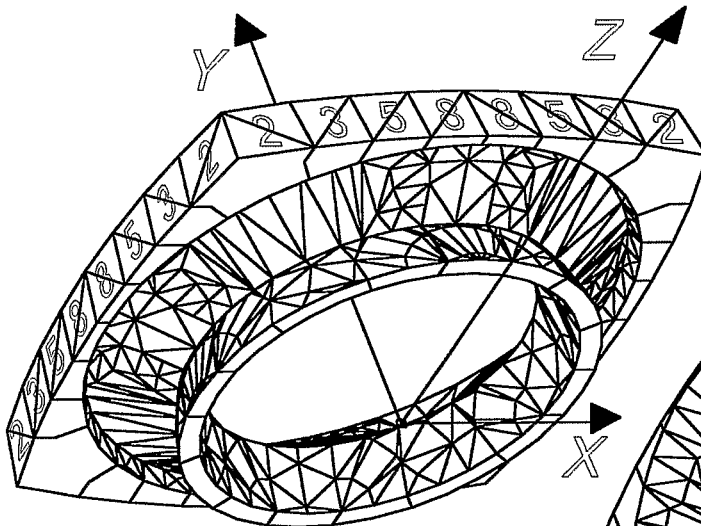
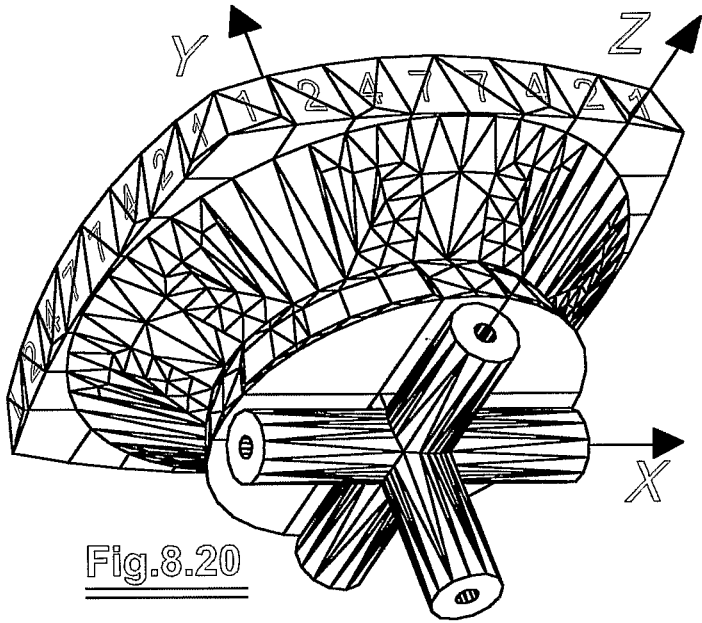

FIGURE 8

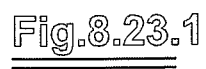
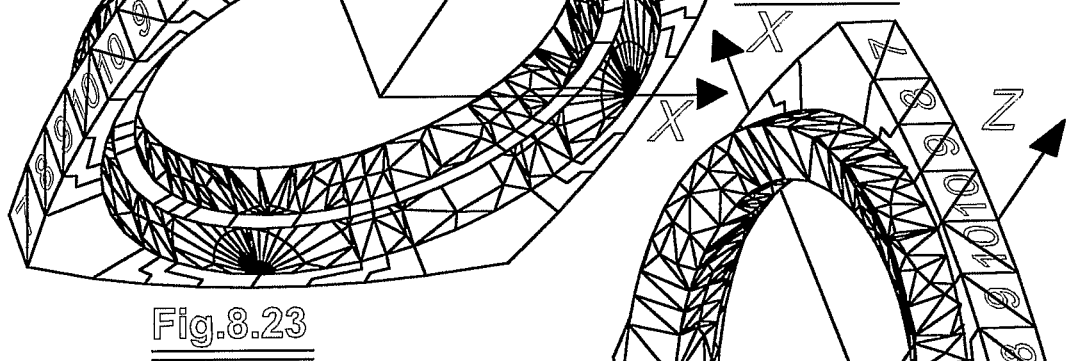
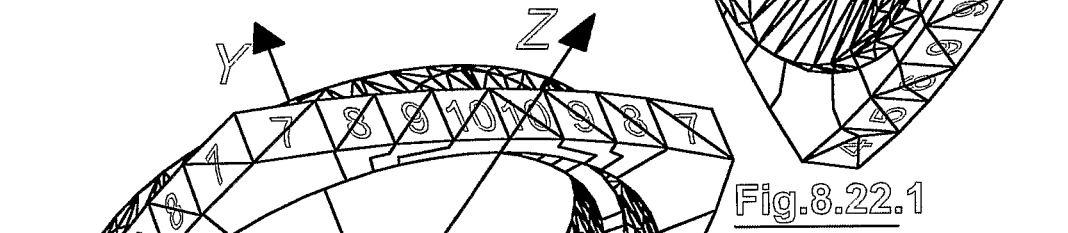
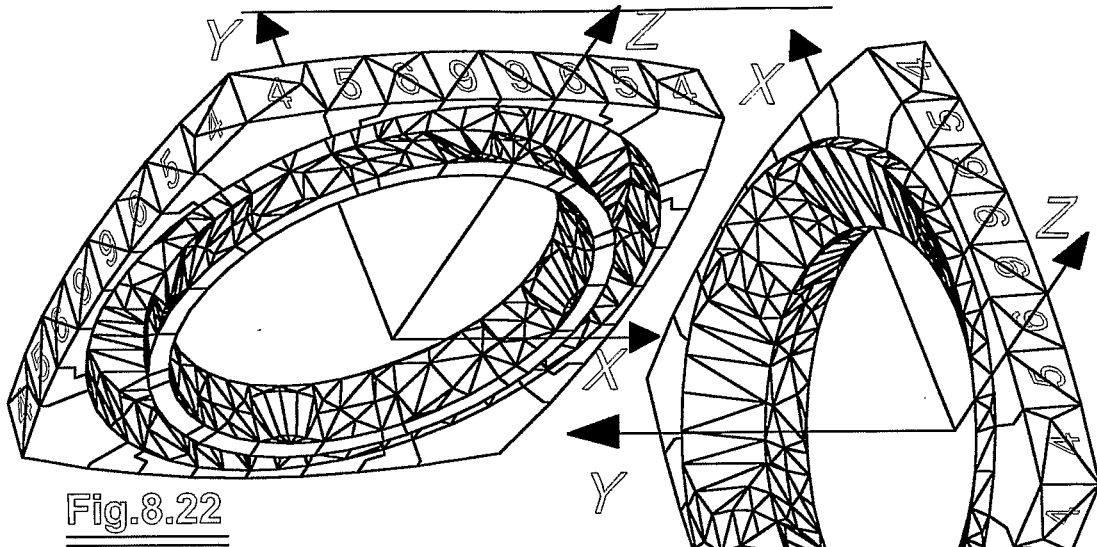

FIGURE 8

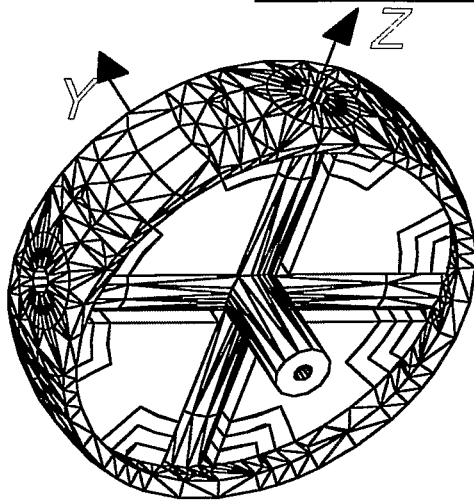

Fig.8.24

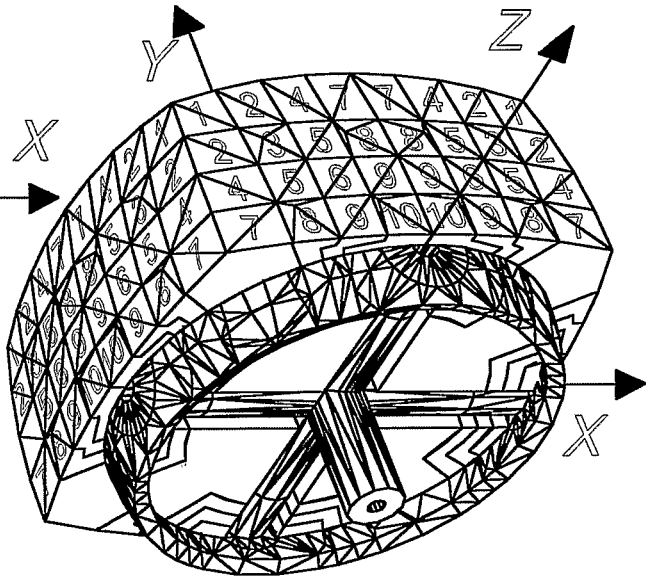

Fig.8.25

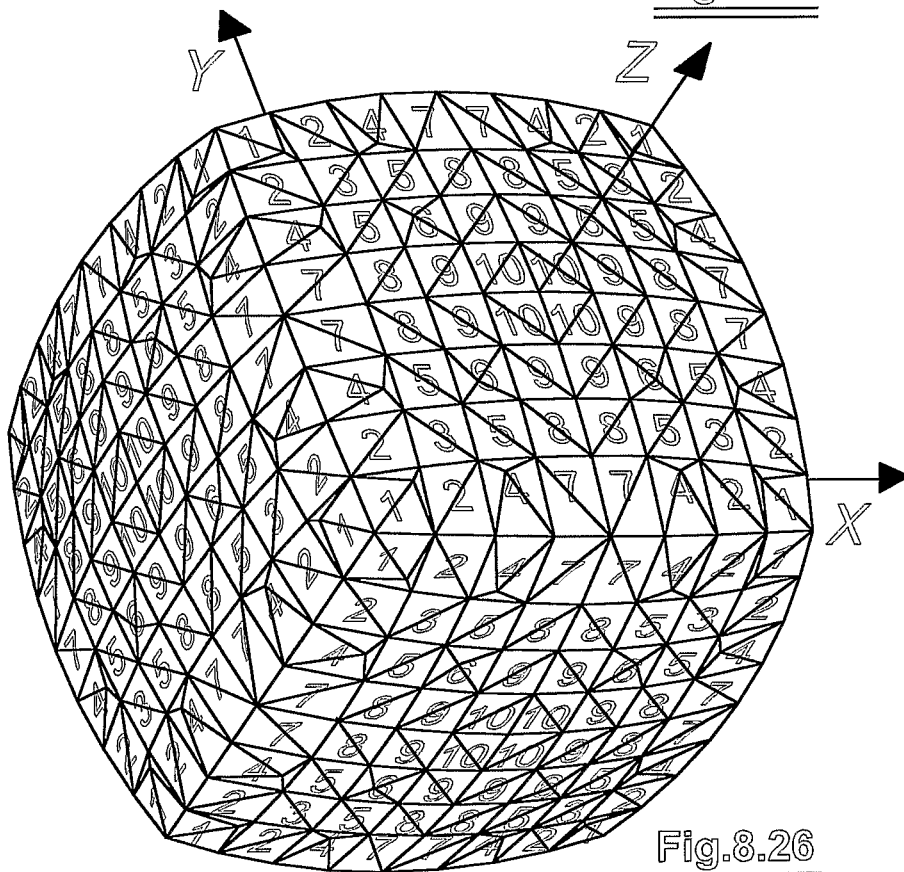

Fig.8.26

FIGURE 9

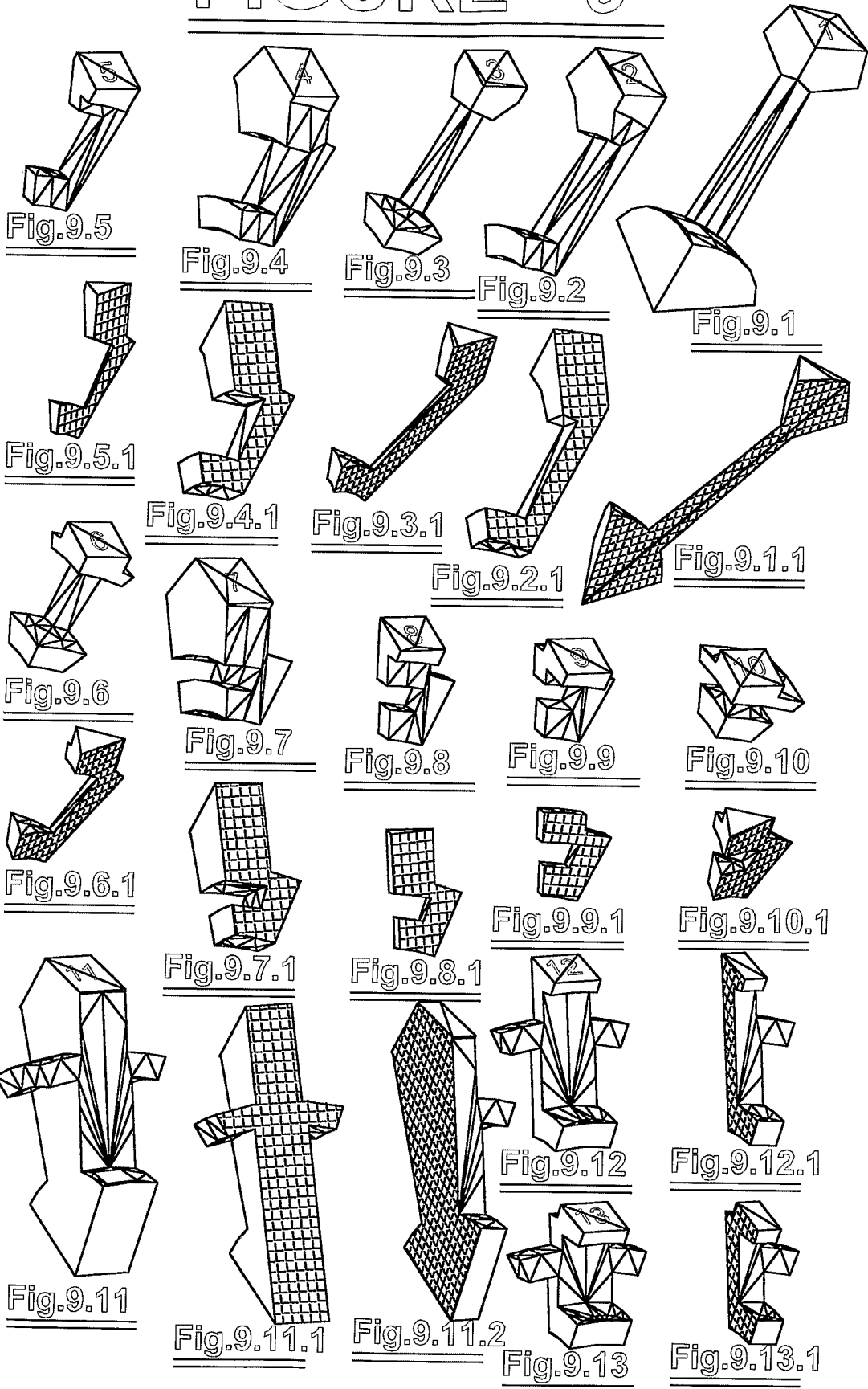

FIGURE 9

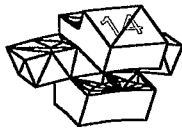

Fig.9.14

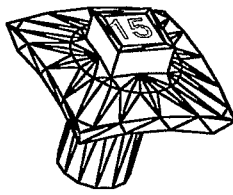

Fig.9.15



Fig.9.14.1

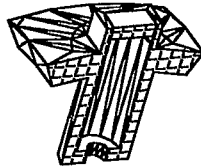

Fig.9.15.1

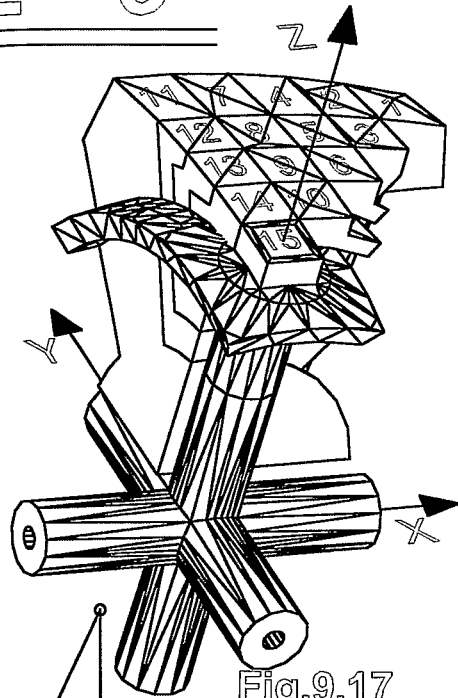

Fig.9.17

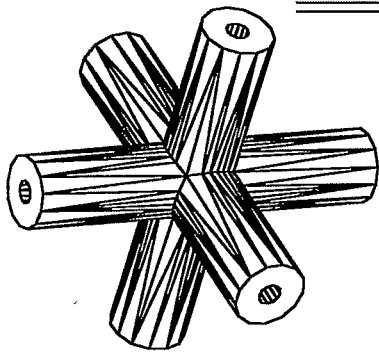

Fig.9.16

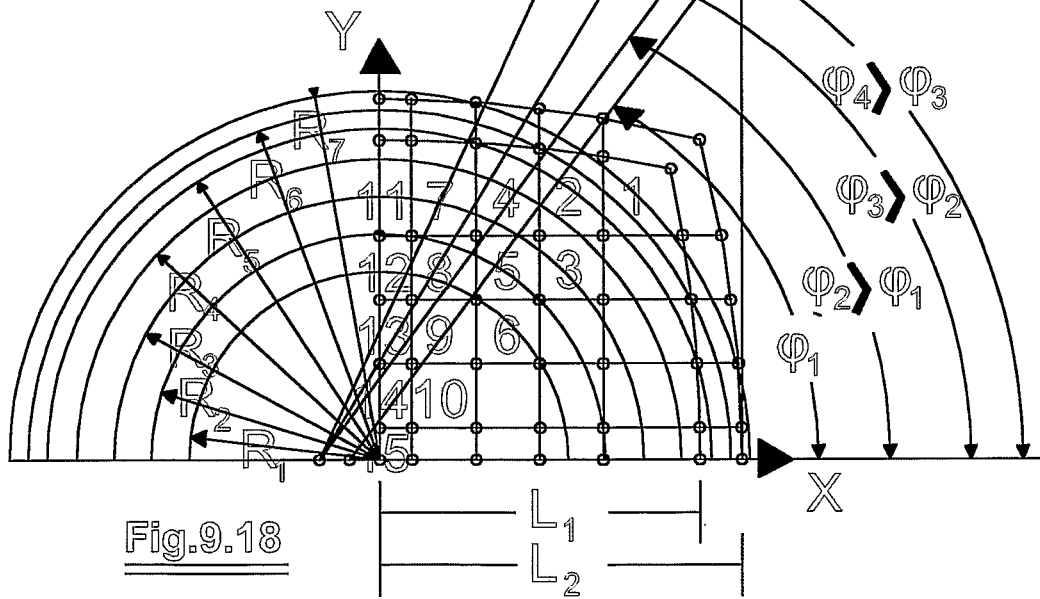

Fig.9.18

FIGURE 9

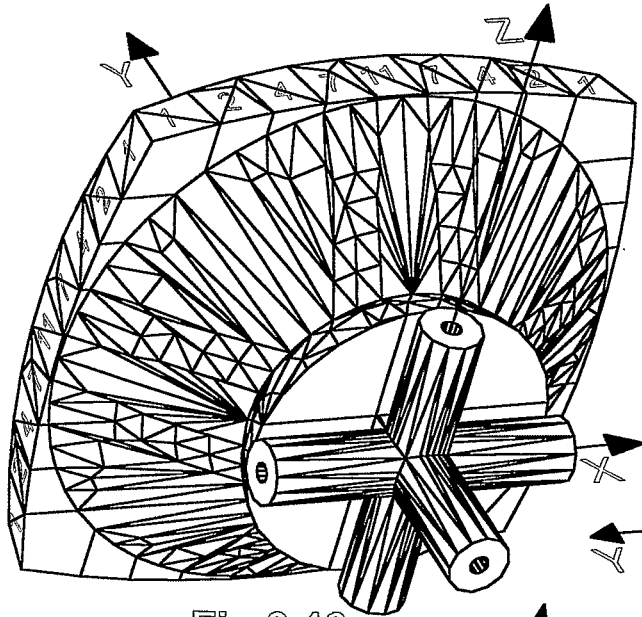

Fig.9.19

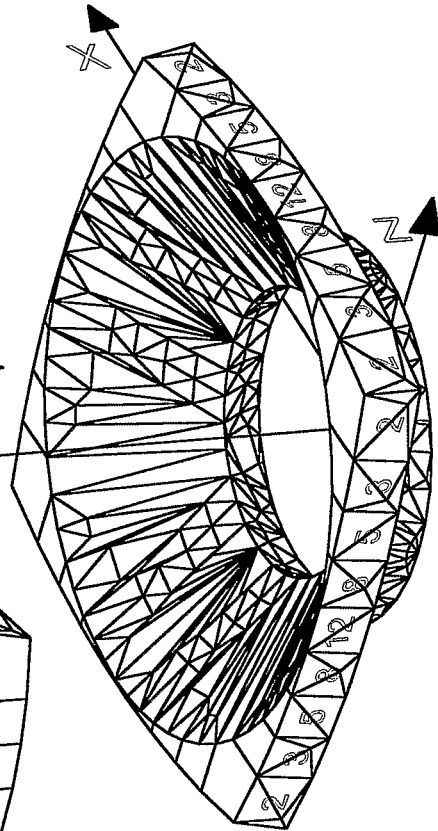

Fig.9.20.1

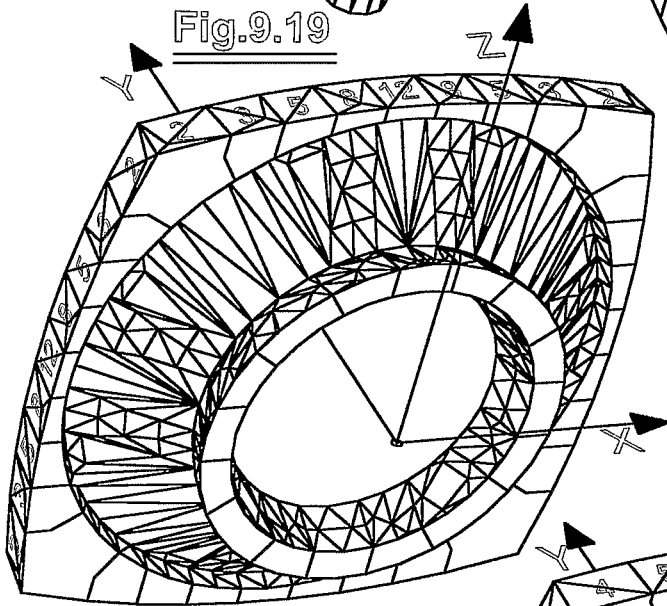

Fig.9.20

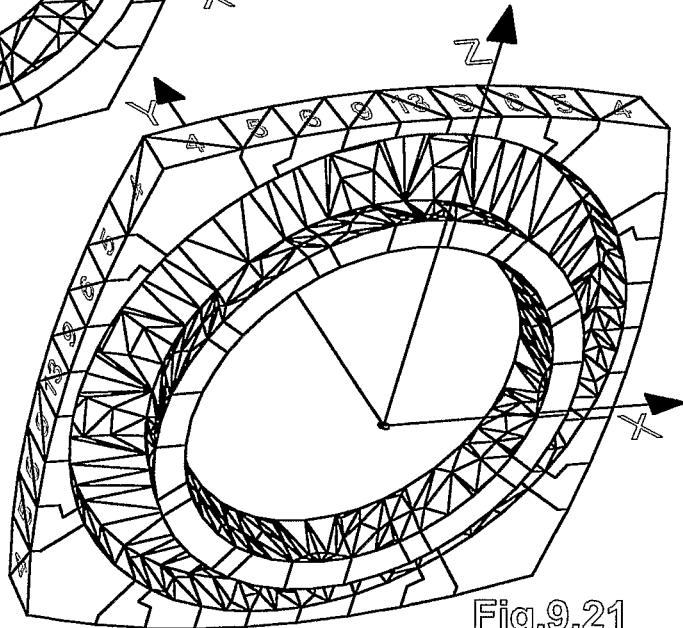

Fig.9.21

FIGURE 9

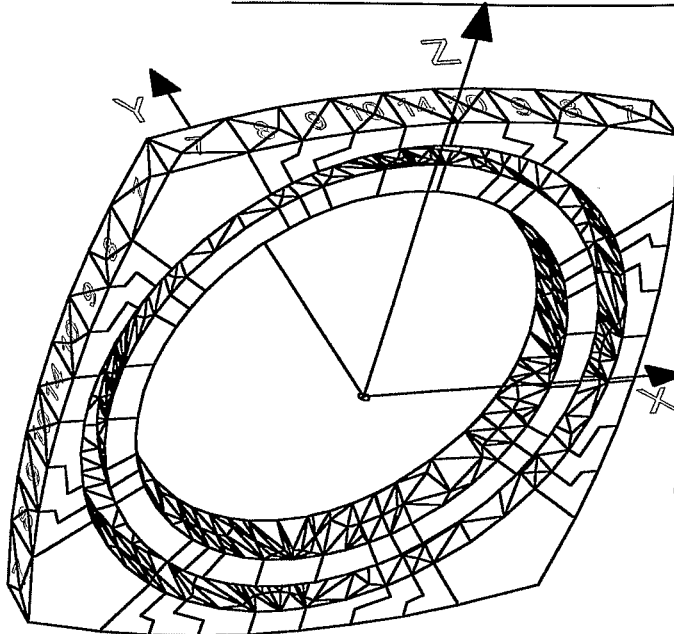

Fig.9.22

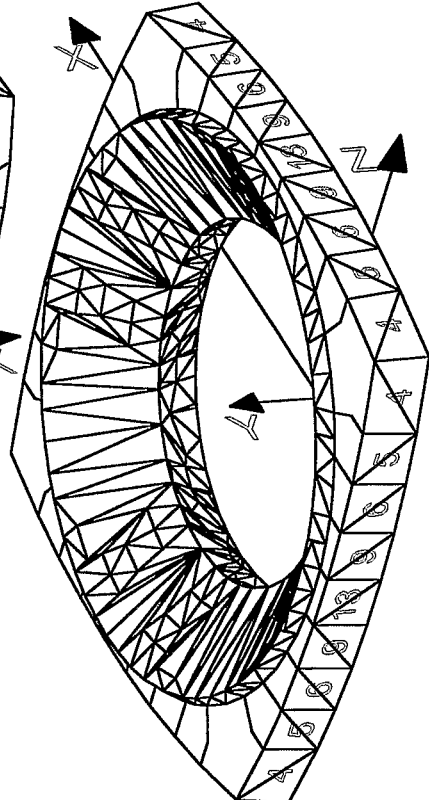

Fig.9.21.1

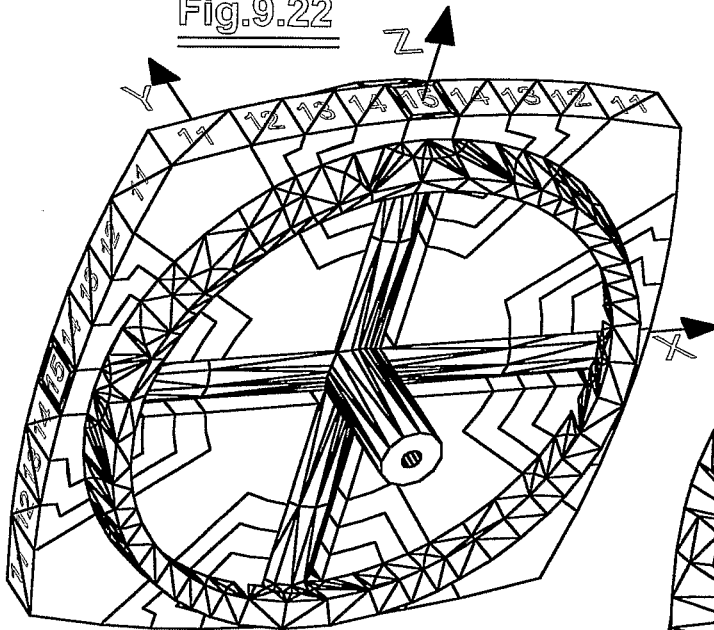

Fig.9.23

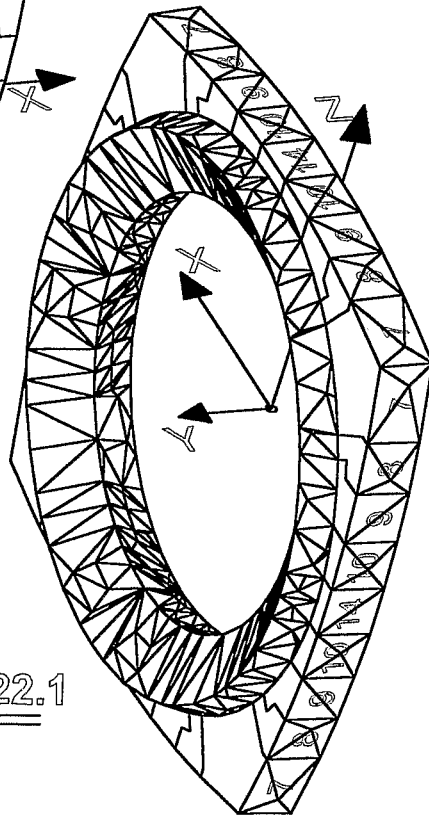

Fig.9.22.1

FIGURE 9

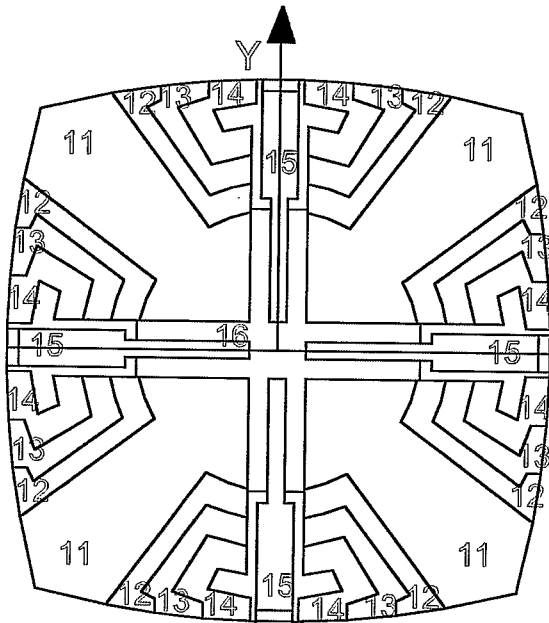

Fig.9.24

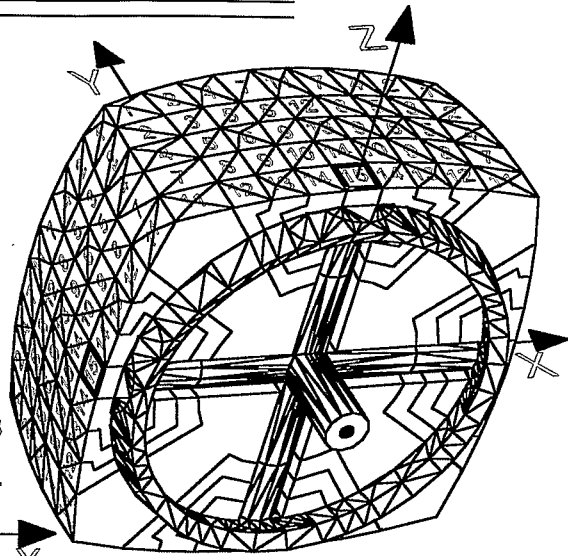

Fig.9.25

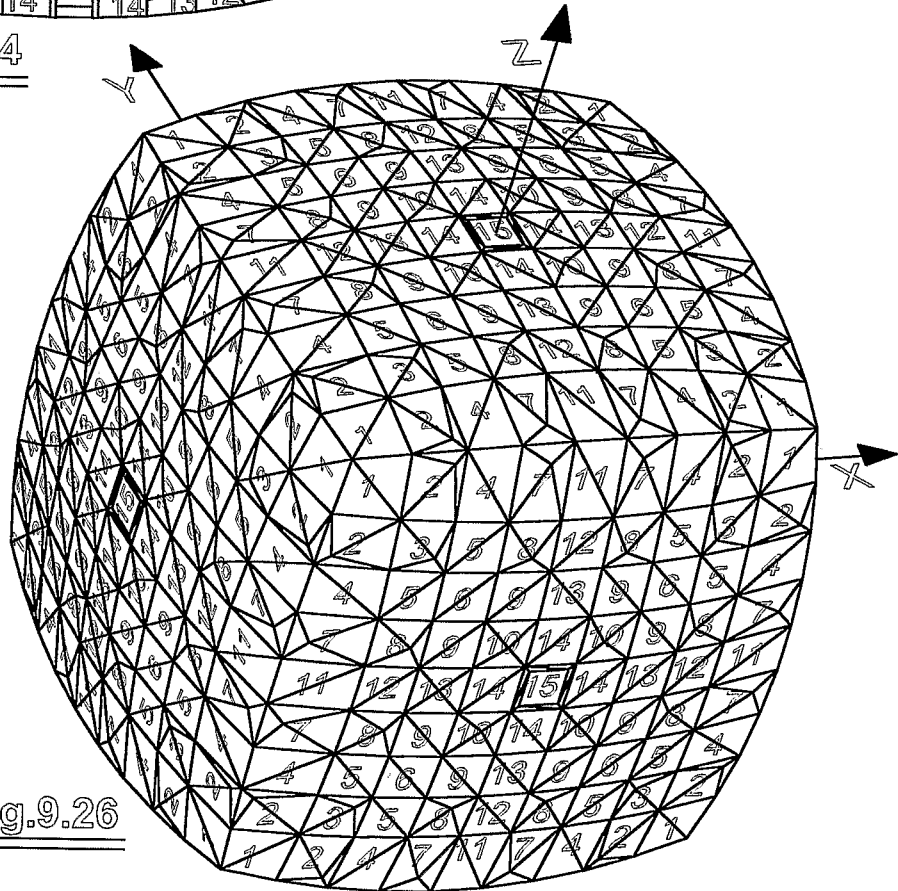

Fig.9.26

FIGURE 10

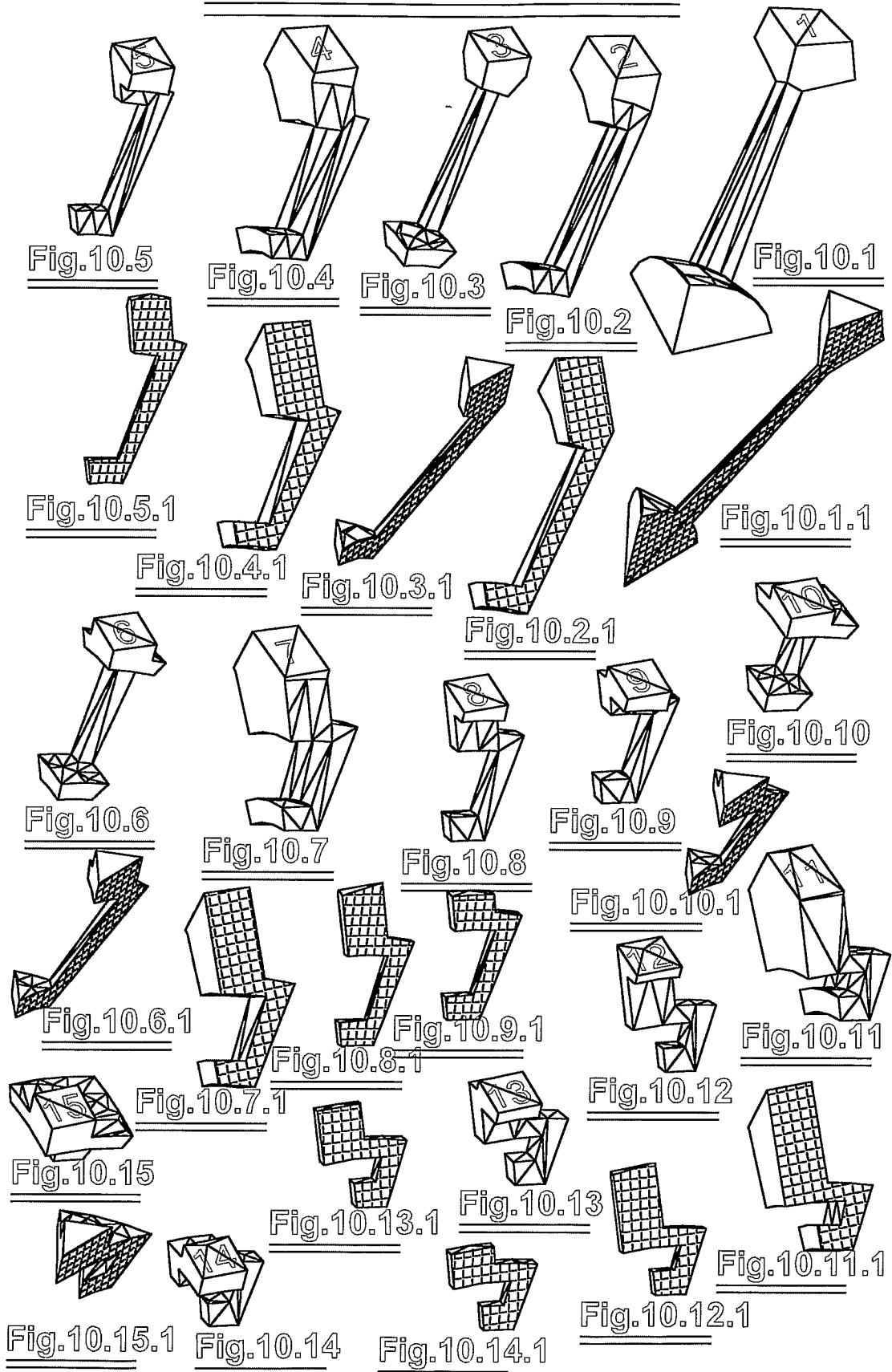

FIGURE 10

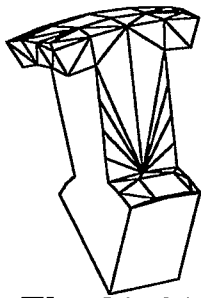

Fig. 10.16

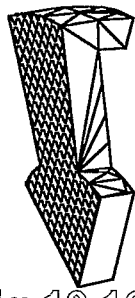

Fig. 10.16.1

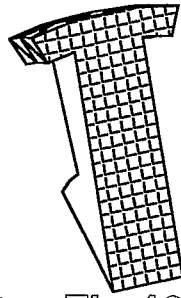

Fig. 10.16.2

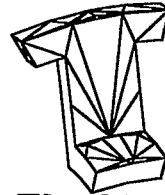

Fig. 10.17



Fig. 10.17.1

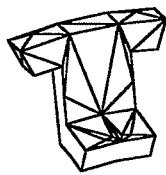

Fig. 10.18

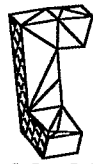

Fig. 10.18.1

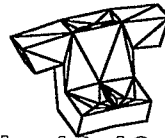

Fig. 10.19

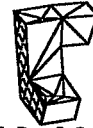

Fig. 10.19.1

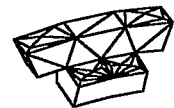

Fig. 10.20



Fig. 10.20.1

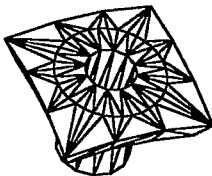

Fig. 10.21

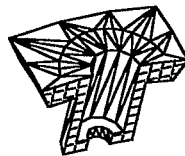

Fig. 10.21.1

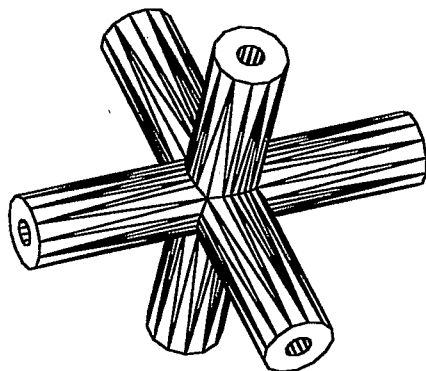

Fig. 10.22

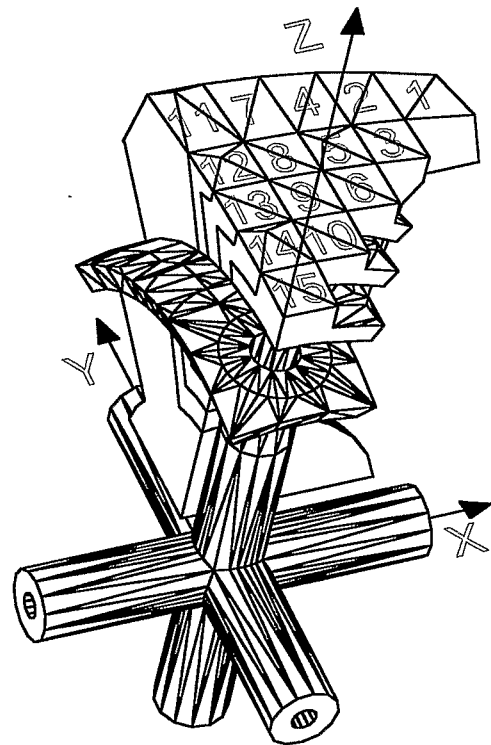

Fig. 10.23

FIGURE 10

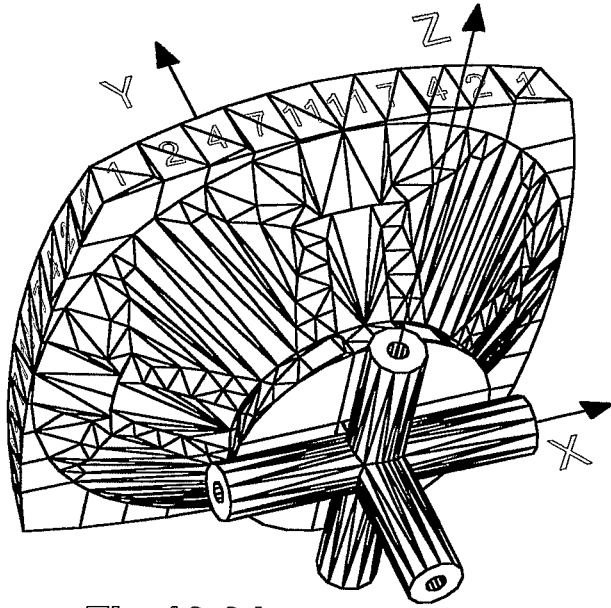

Fig.10.24

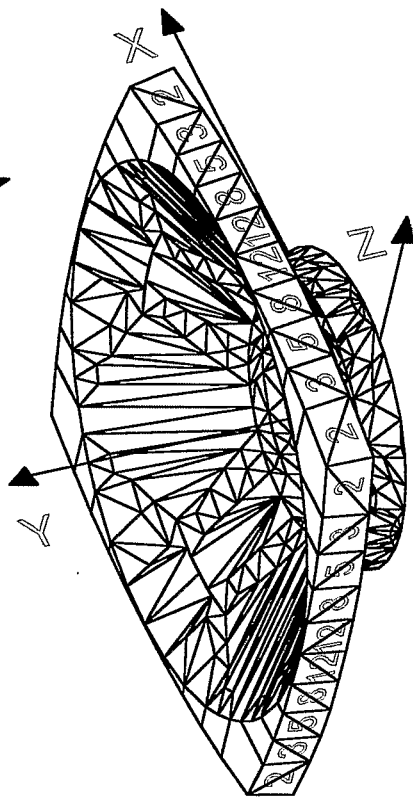

Fig.10.25.1

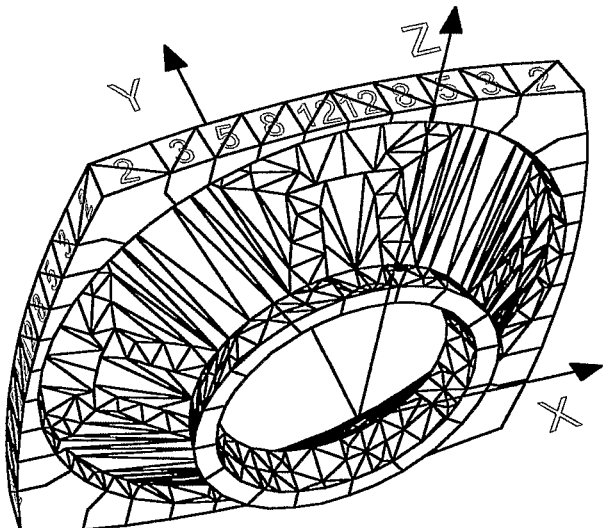

Fig.10.25

FIGURE 10

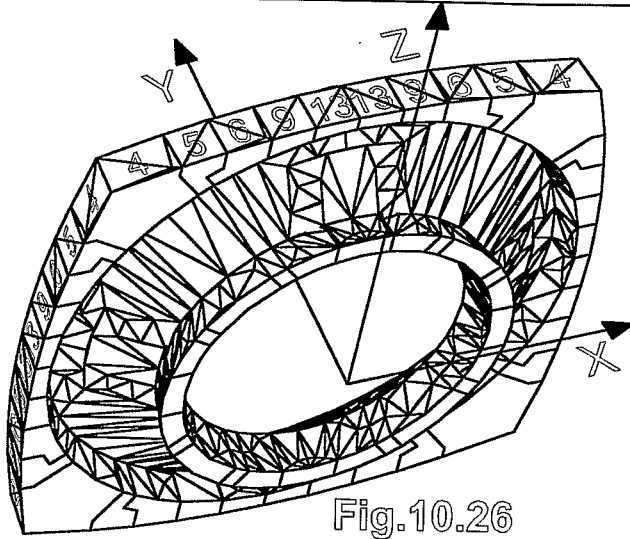

Fig.10.26

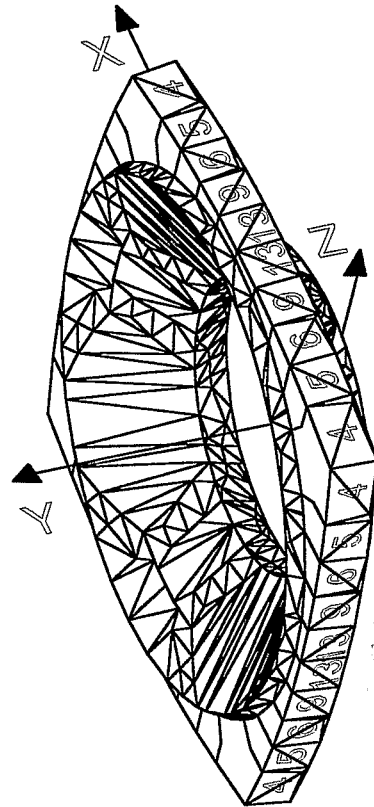

Fig.10.26.1

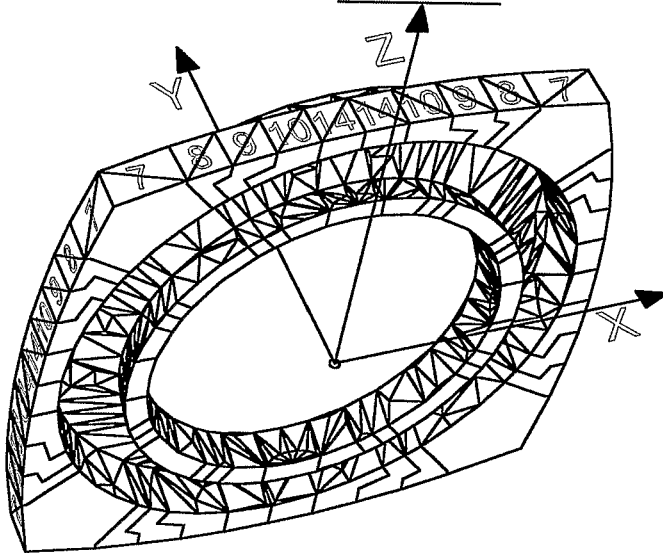

Fig.10.27

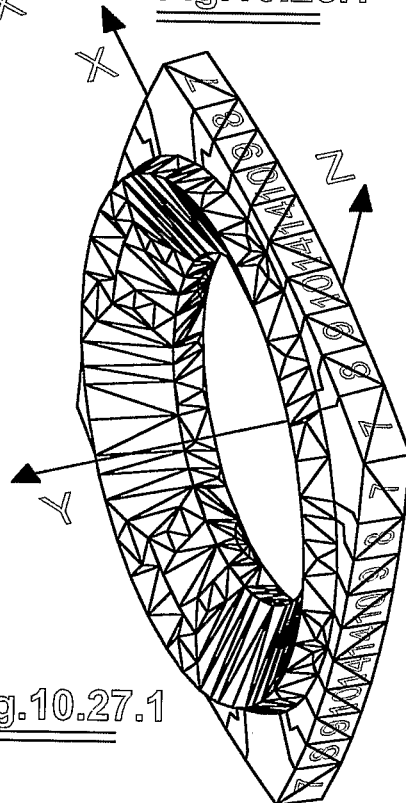

Fig.10.27.1

FIGURE 10

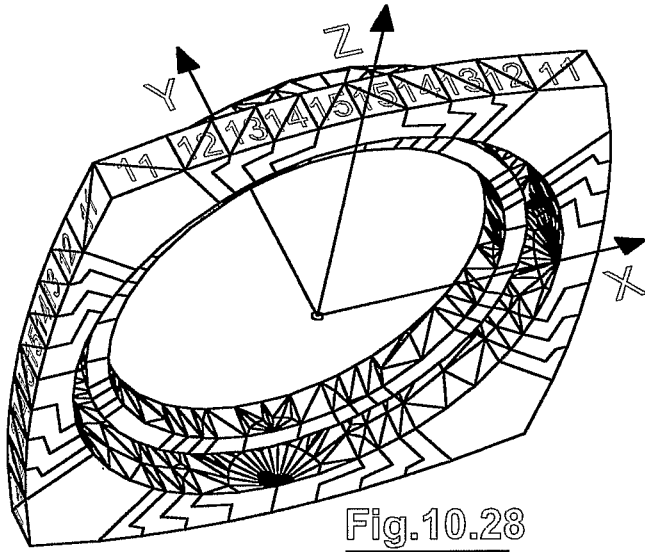

Fig.10.28

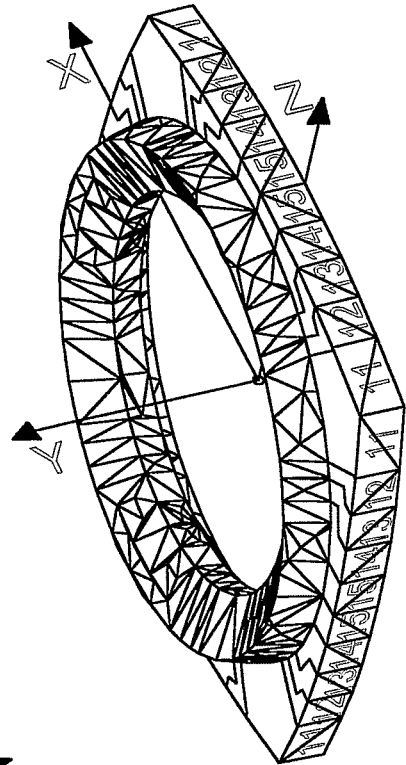

Fig.10.28.1

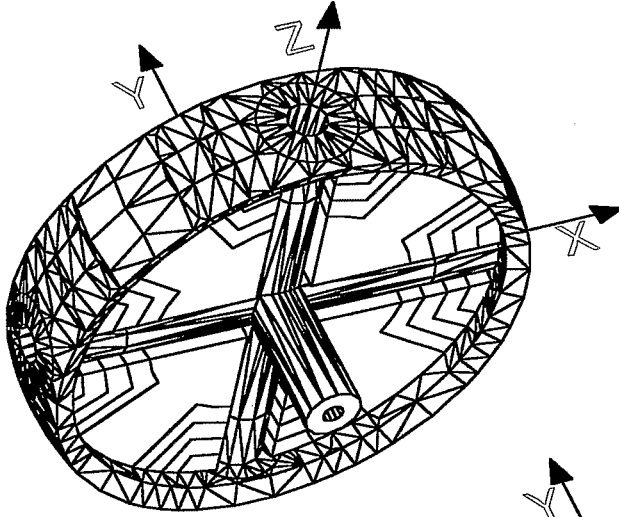

Fig.10.29

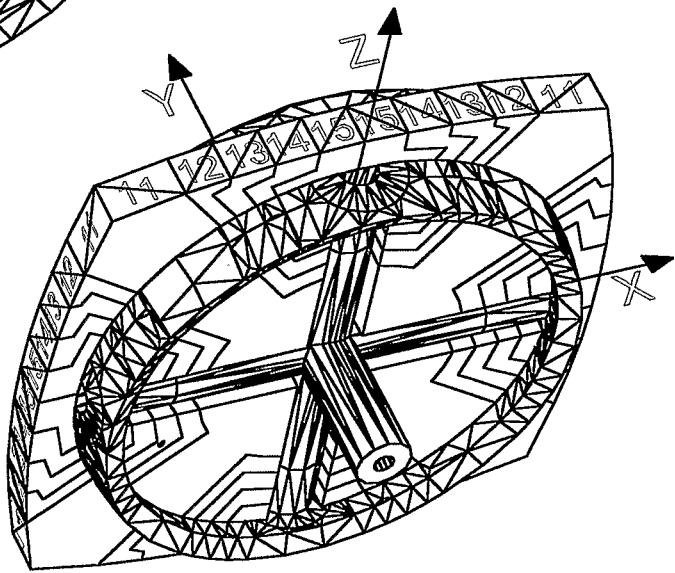

Fig.10.30

FIGURE 10

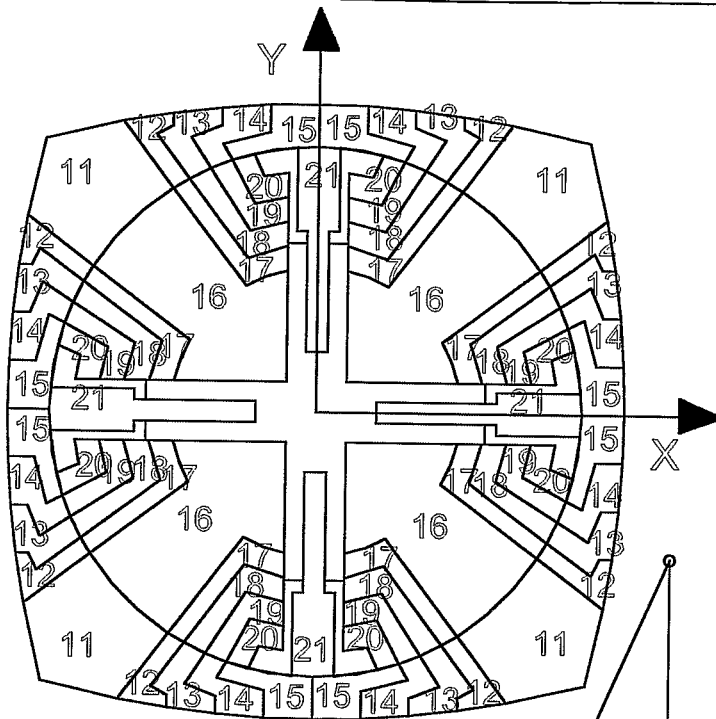

Fig.10.31

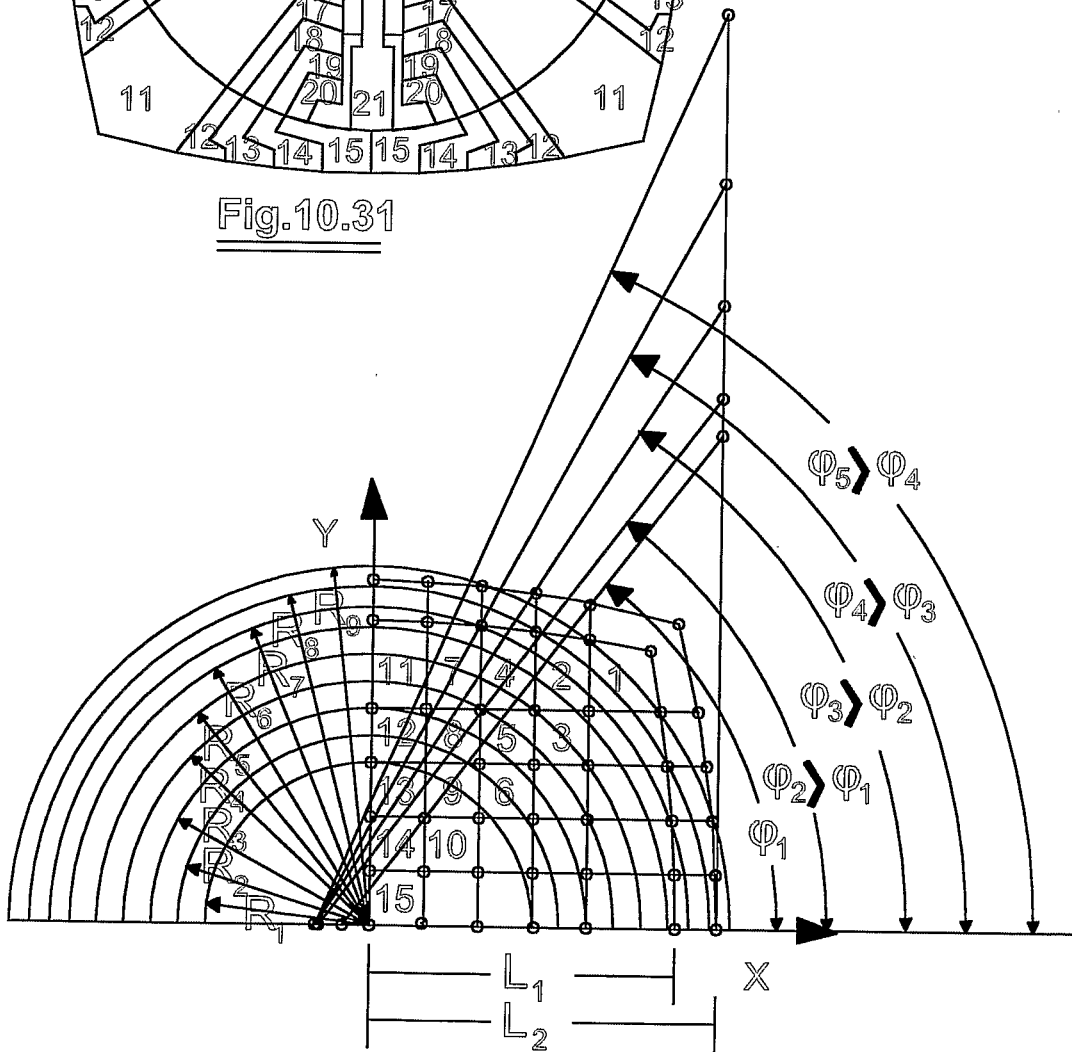

Fig.10.32

FIGURE 10

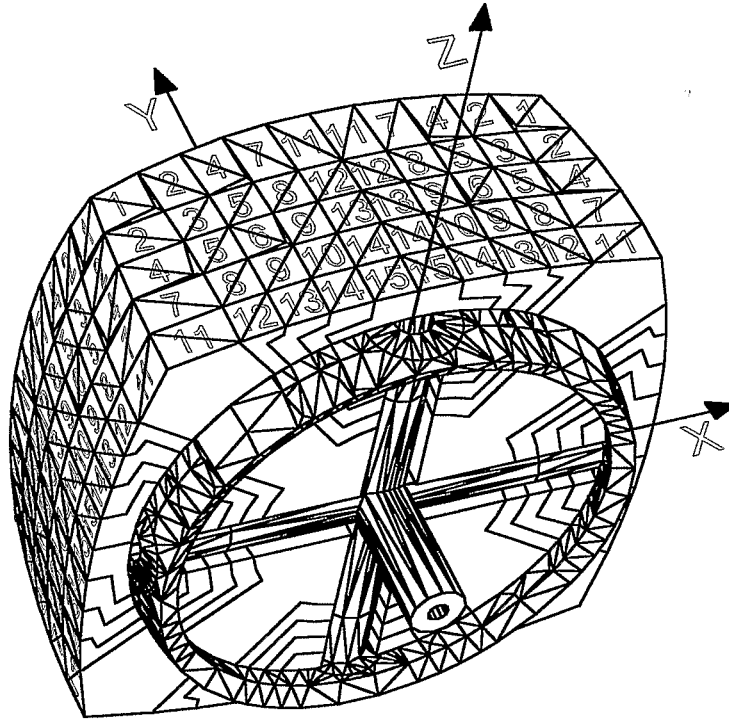

Fig.10.33

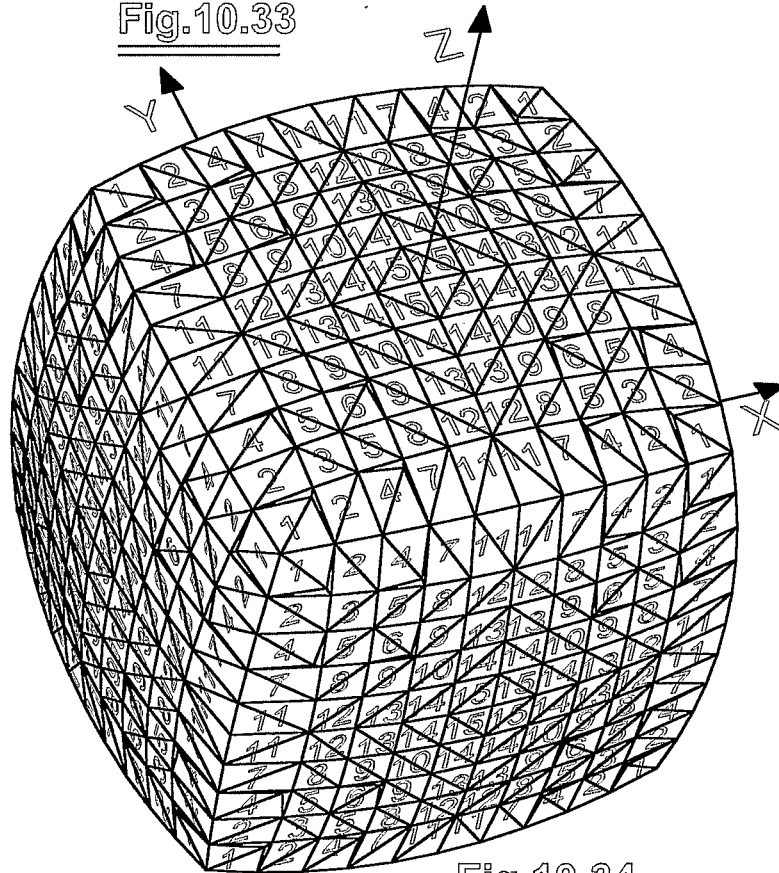

Fig.10.34

FIGURE 11

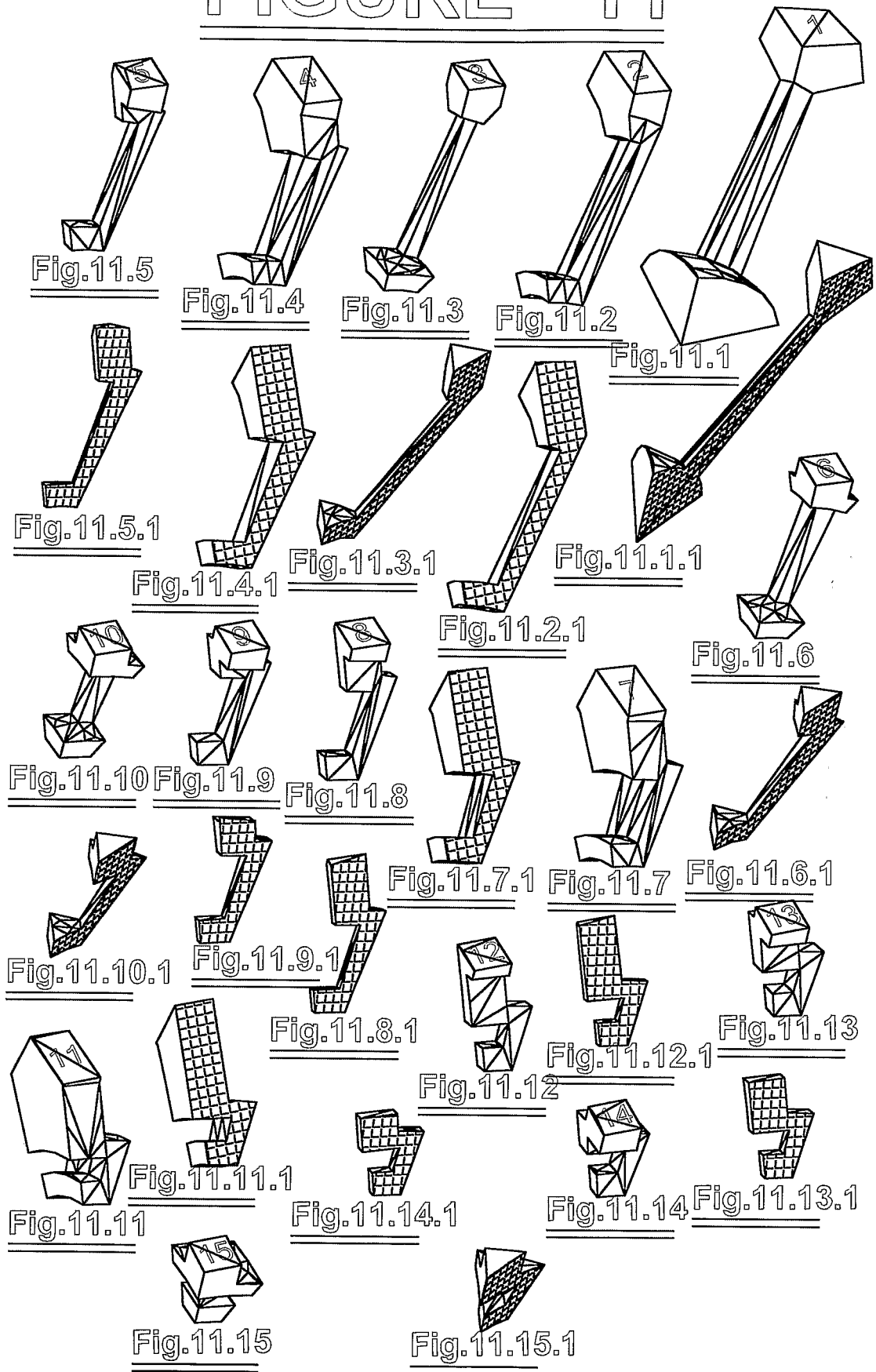

FIGURE 11

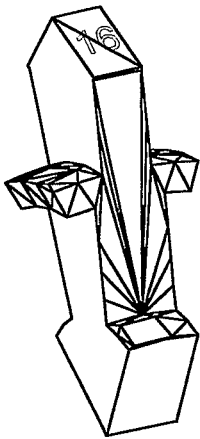

Fig.11.16

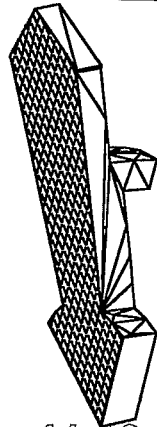

Fig.11.16.1

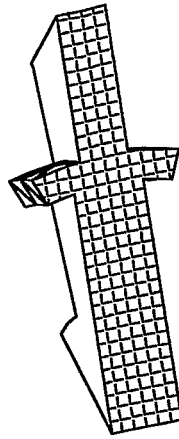

Fig.11.16.2

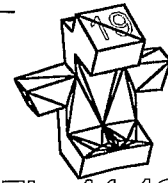

Fig.11.19



Fig.11.19.1

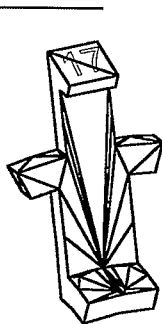

Fig.11.17



Fig.11.17.1

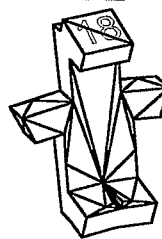

Fig.11.18



Fig.11.18.1



Fig.11.20



Fig.11.20.1

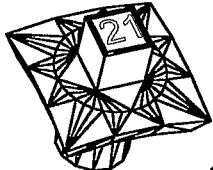

Fig.11.21

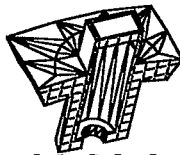

Fig.11.21.1

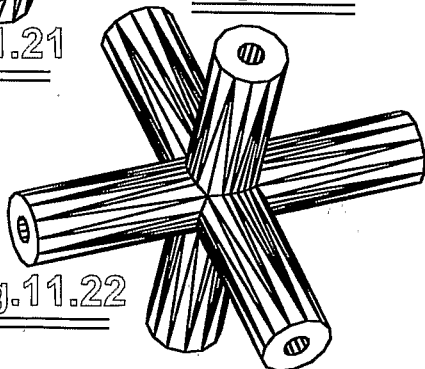

Fig.11.22

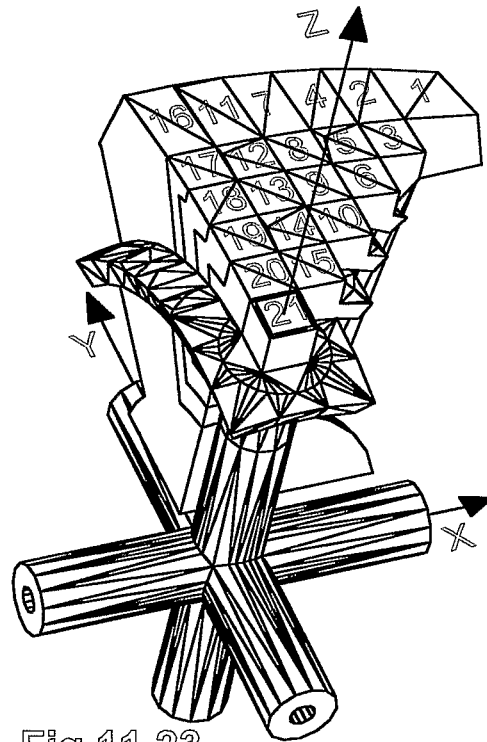

Fig.11.23

FIGURE 11

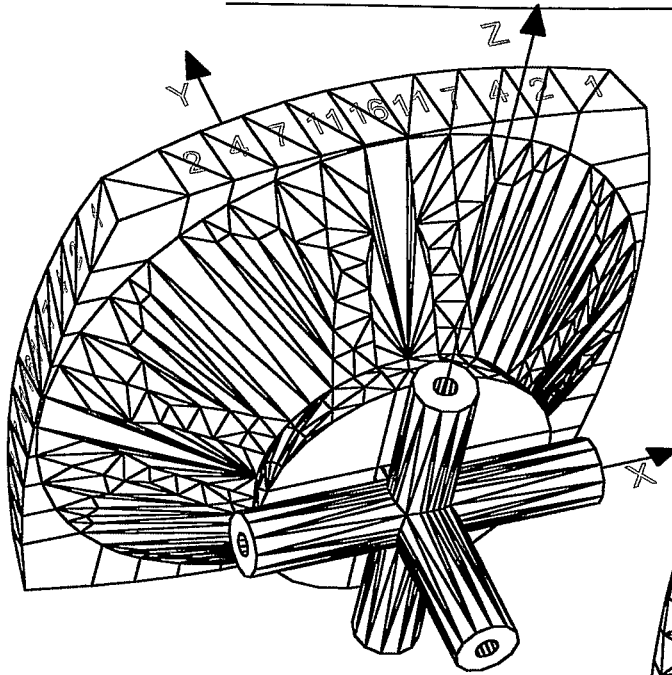

Fig.11.24

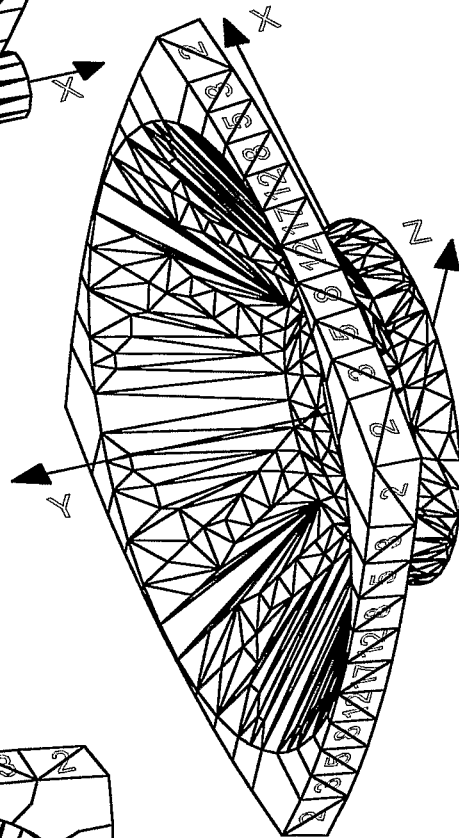

Fig.11.25.1

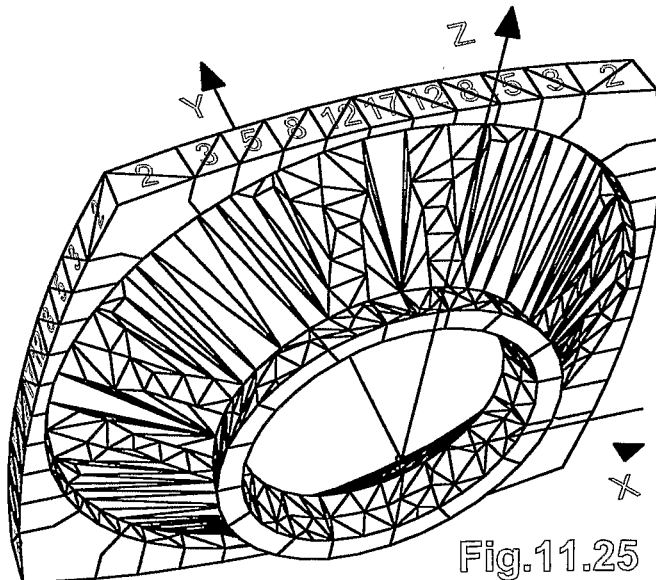

Fig.11.25

FIGURE 11

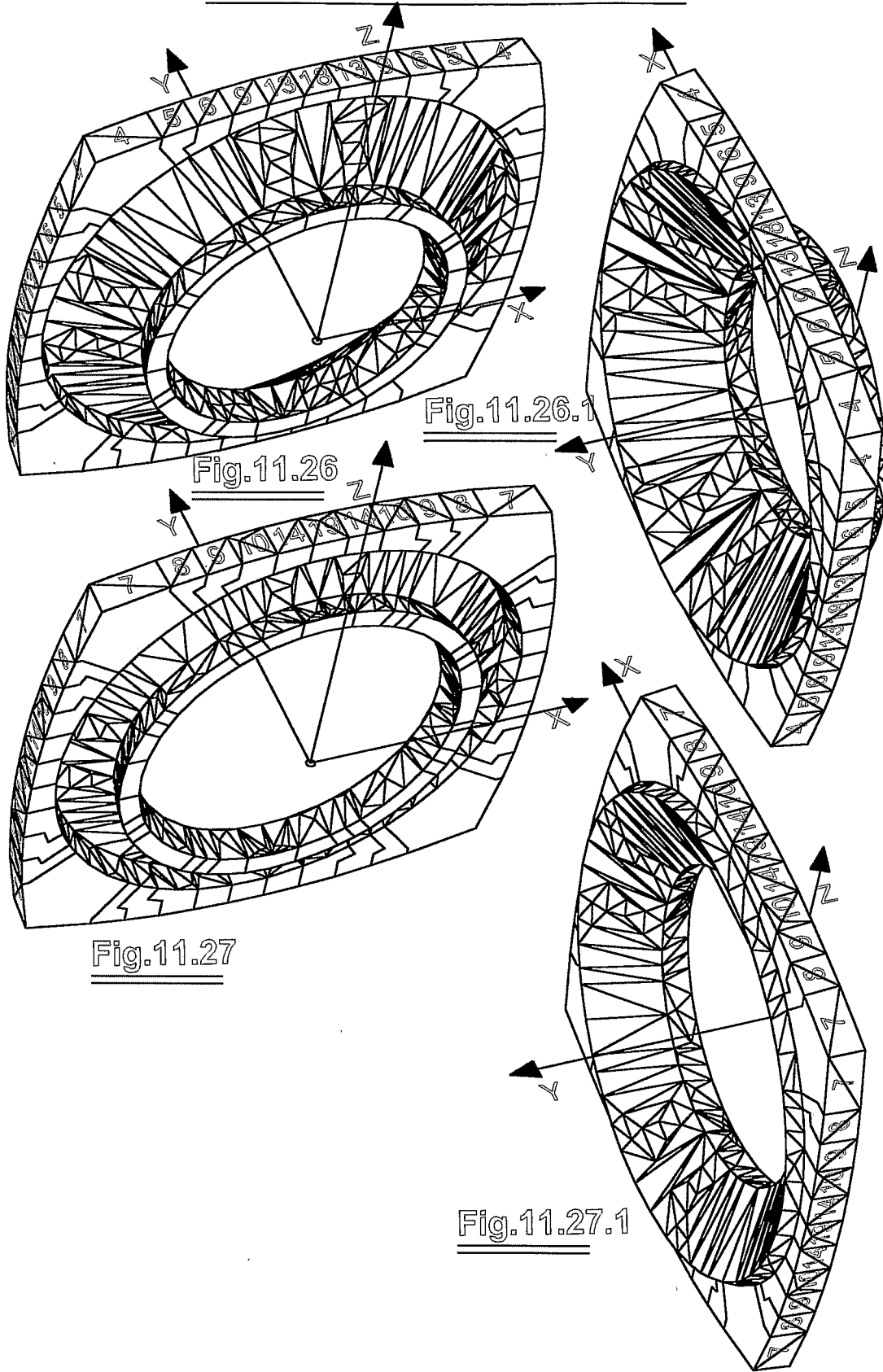

FIGURE 11

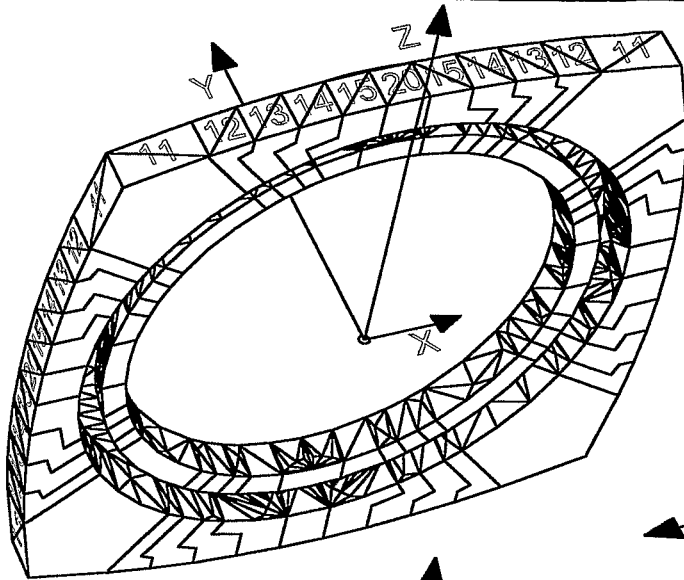

Fig.11.28

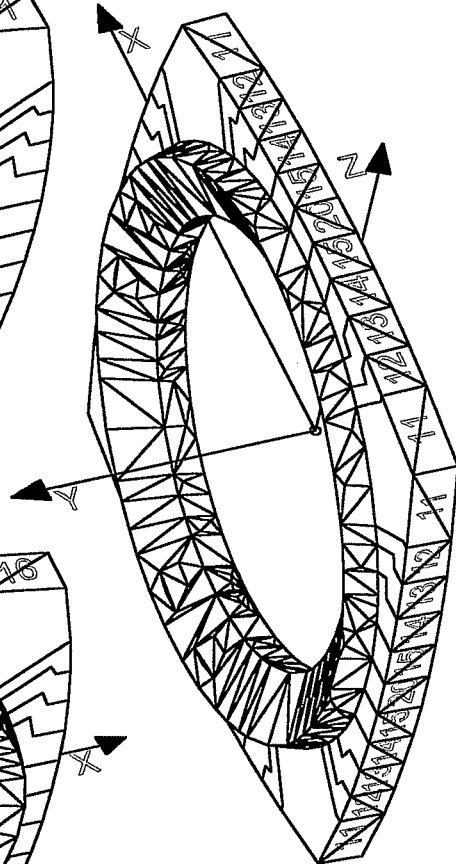

Fig.11.28.1

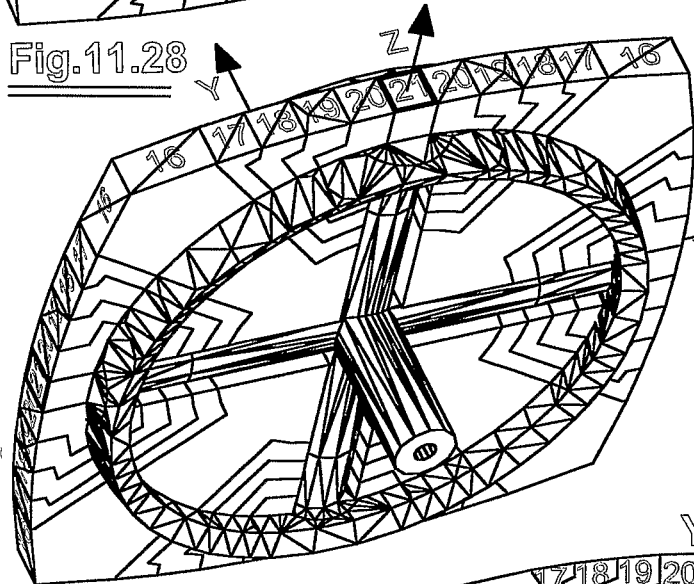

Fig.11.29

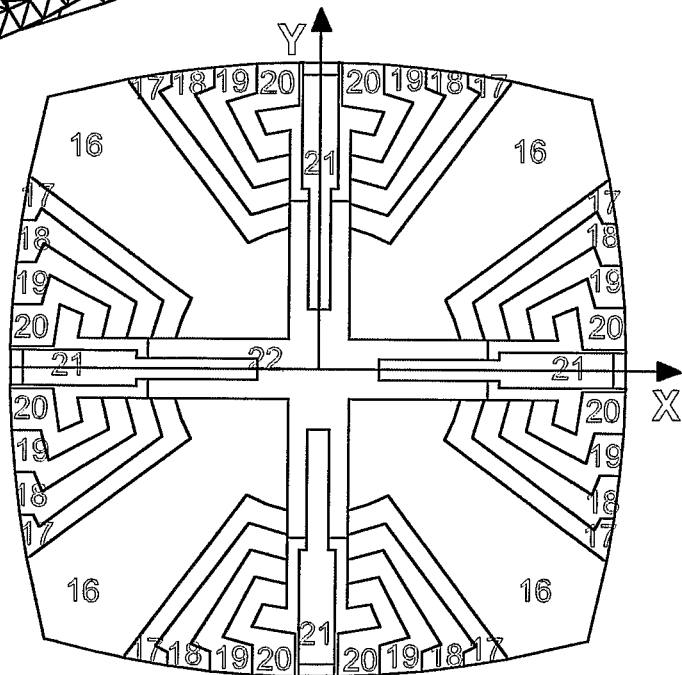

Fig.11.30

FIGURE 11

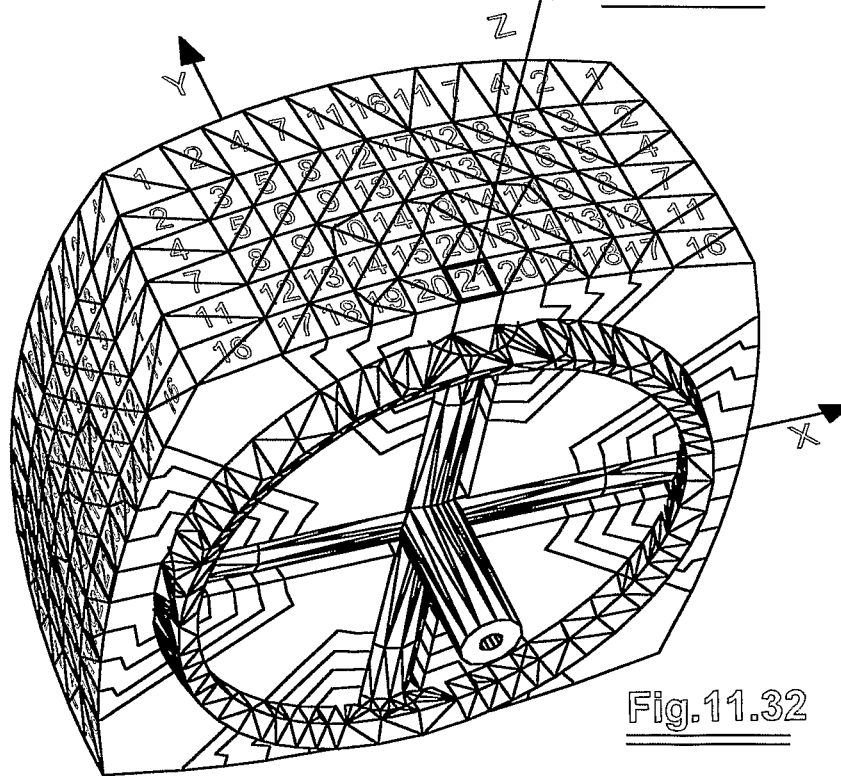
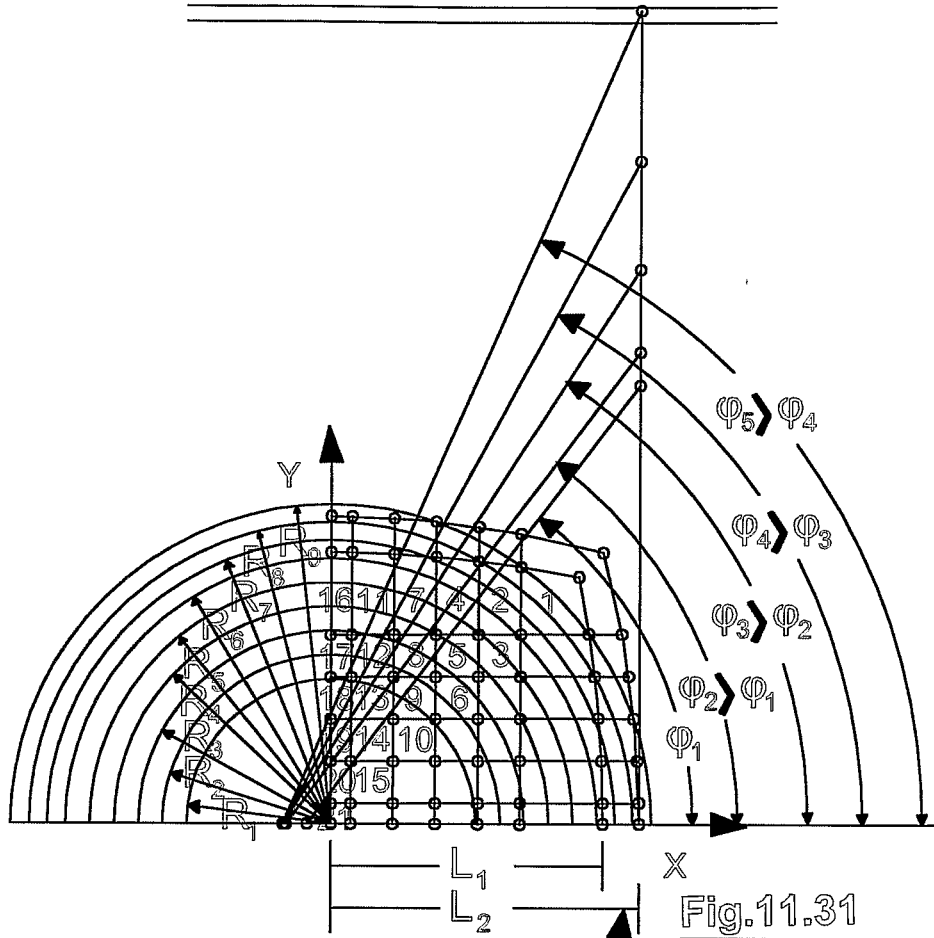

FIGURE 11

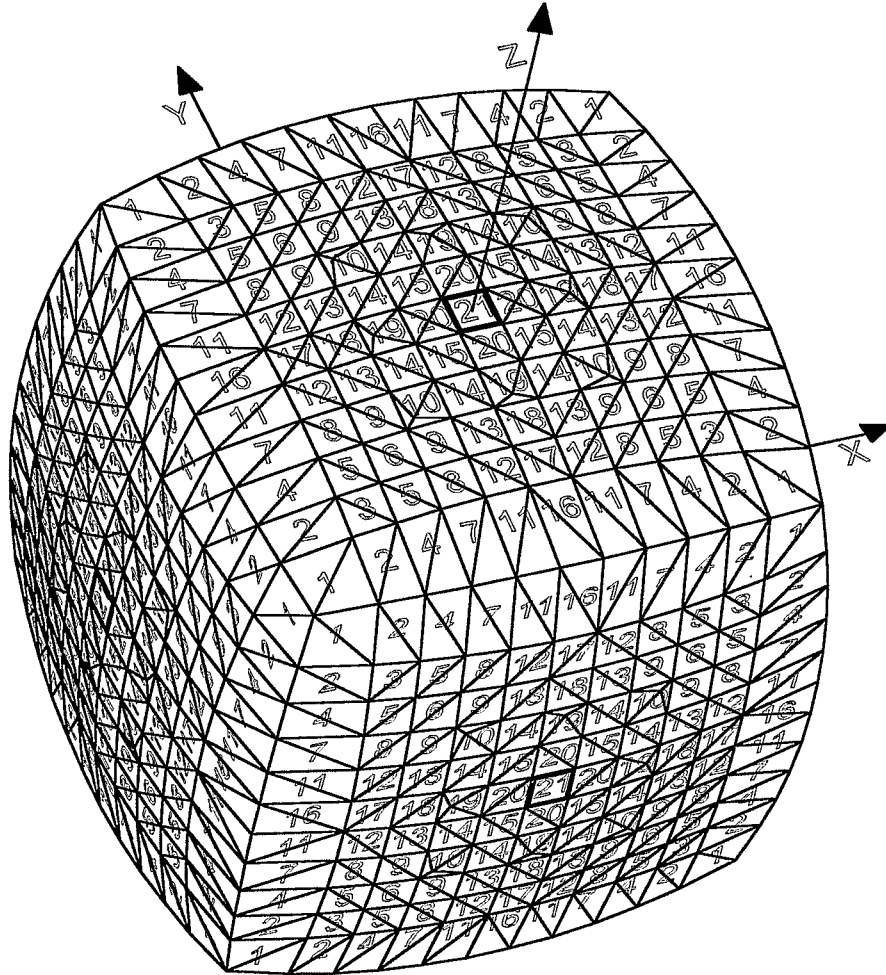

Fig.11.33

INTERNATIONAL SEARCH REPORT

International Application No
PCT/GR2004/000027

A. CLASSIFICATION OF SUBJECT MATTER IPC 7 A63F9/08				
According to International Patent Classification (IPC) or to both national classification and IPC				
B. FIELDS SEARCHED				
Minimum documentation searched (classification system followed by classification symbols) IPC 7 A63F				
Documentation searched other than minimum documentation to the extent that such documents are included in the fields searched				
Electronic data base consulted during the international search (name of data base and, where practical, search terms used) EPO-Internal				
C. DOCUMENTS CONSIDERED TO BE RELEVANT				
Category °	Citation of document, with indication, where appropriate, of the relevant passages	Relevant to claim No.		
X	WO 83/01203 A (TORRES NOEL M) 14 April 1983 (1983-04-14) page 6, line 2 -page 7, line 9; figures 1,2A-2G	1		
A	FR 2 787 033 A (PRIBYL LADISLAV) 16 June 2000 (2000-06-16) page 4, line 14 -page 5, line 27; figures	1		
A	DE 31 11 381 A (OBERMAIER GEB OHG) 7 October 1982 (1982-10-07) the whole document	1		
A	DE 31 25 817 A (HOFMANN JUERGEN) 27 January 1983 (1983-01-27) the whole document	1		
--- -/--				
<input checked="" type="checkbox"/> Further documents are listed in the continuation of box C.				
<input checked="" type="checkbox"/> Patent family members are listed in annex.				
° Special categories of cited documents :				
<table style="width: 100%; border: none;"> <tr> <td style="width: 50%; vertical-align: top; padding: 5px;"> *A* document defining the general state of the art which is not considered to be of particular relevance *E* earlier document but published on or after the international filing date *L* document which may throw doubts on priority claim(s) or which is cited to establish the publication date of another citation or other special reason (as specified) *O* document referring to an oral disclosure, use, exhibition or other means *P* document published prior to the international filing date but later than the priority date claimed </td> <td style="width: 50%; vertical-align: top; padding: 5px;"> *T* later document published after the international filing date or priority date and not in conflict with the application but cited to understand the principle or theory underlying the invention *X* document of particular relevance; the claimed invention cannot be considered novel or cannot be considered to involve an inventive step when the document is taken alone *Y* document of particular relevance; the claimed invention cannot be considered to involve an inventive step when the document is combined with one or more other such documents, such combination being obvious to a person skilled in the art. *&* document member of the same patent family </td> </tr> </table>			*A* document defining the general state of the art which is not considered to be of particular relevance *E* earlier document but published on or after the international filing date *L* document which may throw doubts on priority claim(s) or which is cited to establish the publication date of another citation or other special reason (as specified) *O* document referring to an oral disclosure, use, exhibition or other means *P* document published prior to the international filing date but later than the priority date claimed	*T* later document published after the international filing date or priority date and not in conflict with the application but cited to understand the principle or theory underlying the invention *X* document of particular relevance; the claimed invention cannot be considered novel or cannot be considered to involve an inventive step when the document is taken alone *Y* document of particular relevance; the claimed invention cannot be considered to involve an inventive step when the document is combined with one or more other such documents, such combination being obvious to a person skilled in the art. *&* document member of the same patent family
A document defining the general state of the art which is not considered to be of particular relevance *E* earlier document but published on or after the international filing date *L* document which may throw doubts on priority claim(s) or which is cited to establish the publication date of another citation or other special reason (as specified) *O* document referring to an oral disclosure, use, exhibition or other means *P* document published prior to the international filing date but later than the priority date claimed	*T* later document published after the international filing date or priority date and not in conflict with the application but cited to understand the principle or theory underlying the invention *X* document of particular relevance; the claimed invention cannot be considered novel or cannot be considered to involve an inventive step when the document is taken alone *Y* document of particular relevance; the claimed invention cannot be considered to involve an inventive step when the document is combined with one or more other such documents, such combination being obvious to a person skilled in the art. *&* document member of the same patent family			
Date of the actual completion of the international search <p style="text-align: center;">4 August 2004</p>	Date of mailing of the international search report <p style="text-align: center;">11/08/2004</p>			
Name and mailing address of the ISA European Patent Office, P.B. 5818 Patentlaan 2 NL - 2280 HV Rijswijk Tel. (+31-70) 340-2040, Tx. 31 651 epo nl, Fax: (+31-70) 340-3016	Authorized officer <p style="text-align: center;">Turmo Peruga, R</p>			

INTERNATIONAL SEARCH REPORT

International Application No
PCT/GR2004/000027

C.(Continuation) DOCUMENTS CONSIDERED TO BE RELEVANT

Category °	Citation of document, with indication, where appropriate, of the relevant passages	Relevant to claim No.
A	DE 31 33 235 A (KOLLODZEY WILLFRED;VU HAN VIET DIPL ING) 10 March 1983 (1983-03-10) the whole document -----	1
A	US 6 129 356 A (LI CHEN SEN) 10 October 2000 (2000-10-10) the whole document -----	1

INTERNATIONAL SEARCH REPORT

 International Application No
 PCT/GR2004/000027

Patent document cited in search report		Publication date		Patent family member(s)	Publication date
WO 8301203	A	14-04-1983	AU	8080782 A	27-04-1983
			EP	0090806 A1	12-10-1983
			WO	8301203 A1	14-04-1983
FR 2787033	A	16-06-2000	DE	29921299 U1	27-01-2000
			ES	1044740 U1	01-06-2000
			FR	2787033 A1	16-06-2000
			IT	MI990749 U1	14-06-2001
DE 3111381	A	07-10-1982	DE	3111381 A1	07-10-1982
DE 3125817	A	27-01-1983	DE	3125817 A1	27-01-1983
DE 3133235	A	10-03-1983	DE	3133235 A1	10-03-1983
US 6129356	A	10-10-2000	BR	9802233 A	25-04-2000
			CA	2237262 A1	11-11-1999
			FR	2779358 A1	10-12-1999
			SG	73512 A1	20-06-2000
			ZA	9804034 A	13-11-1998
			AU	6481998 A	18-11-1999